

This manual should be considered a permanent part of the vehicle and should remain with the vehicle when it is resold.

This publication includes the latest production information available before printing. Honda Motor Co., Ltd. reserves the right to make changes at any time without notice and without incurring any obligation.

No part of this publication may be reproduced without written permission.

The vehicle pictured in this owner's manual may not match your actual vehicle.

For any query or assistance, please call Customer care number:
1800 103 3434 (Toll free)

Welcome

Congratulations on your purchase of a new Honda vehicle. Your selection of a Honda makes you part of a worldwide family of satisfied customers who appreciate Honda's reputation for building quality into every product.

To ensure your safety and riding pleasure:

- Read this owner's manual carefully.
- Follow all recommendations and procedures contained in this manual.
- Pay close attention to safety messages contained in this manual and on the vehicle.

- The following codes in this manual indicate the destination.
- The illustrations here in are based on the SCV110S II ID type.

Destination Codes

Code	Destination
-------------	--------------------

SCV110S	
----------------	--

ID, II ID	India
-----------	-------

A Few Words About Safety

Your safety, and the safety of others, is very important. Operating this vehicle safely is an important responsibility.

To help you make informed decisions about safety, we have provided operating procedures and other information on safety labels and in this manual. This information alerts you to potential hazards that could hurt you or others.

Of course, it is not practical or possible to warn you about all hazards associated with operating or maintaining a vehicle. You must use your own good judgement.

You will find important safety information in a variety of forms, including:

- Safety labels on the vehicle
- Safety Messages preceded by a safety alert symbol  and one of three signal words: DANGER, WARNING, or CAUTION.

These signal words mean:

DANGER

You **WILL** be **KILLED** or **SERIOUSLY HURT** if you don't follow instructions.

WARNING

You **CAN** be **KILLED** or **SERIOUSLY HURT** if you don't follow instructions.

CAUTION

You **CAN** be **HURT** if you don't follow instructions.

Other important information is provided under the following titles:

NOTICE Information to help you avoid damage to your vehicle, other property, or the environment.

Contents

Vehicle Safety P. 2

Operation Guide P. 14

Maintenance P. 50

Troubleshooting P. 90

Information P. 108

Specifications P. 122

Warranty Policy P. 125

Index P. 133

Vehicle Safety

This section contains important information for safe riding of your vehicle.
Please read this section carefully.

Safety Guidelines	P. 3
Image Labels	P. 6
Safety Precautions	P. 8
Riding Precautions	P. 9
Accessories & Modifications	P. 12
Loading	P. 13

Safety Guidelines

Follow these guidelines to enhance your safety:

- Perform all routine and regular inspections specified in this manual.
- Stop the engine and keep sparks and flames away before filling the fuel tank.
- Do not run the engine in enclosed or partly enclosed areas. Carbon monoxide in exhaust gases is toxic and can kill you.

Always Wear a Helmet

It's a proven fact: helmets and protective apparel significantly reduce the number and severity of head and other injuries. So always wear an approved helmet and protective apparel. 📖P. 8

Before Riding

Make sure that you are physically fit, mentally focused, and free of alcohol and drugs. Check

that you and your passenger are both wearing an approved helmet and protective apparel. Instruct your passenger on holding onto the grab rail or your waist, leaning with you in turns, and keeping their feet on the footpegs, even when the vehicle is stopped.

Take Time to Learn & Practice

Even if you have ridden other vehicles, practice riding in a safe area to become familiar with how this vehicle works and handles, and to become accustomed to the vehicle's size and weight.

Ride Defensively

Always pay attention to other vehicles around you, and do not assume that other drivers see you. Be prepared to stop quickly or perform an evasive maneuver.

Safety Guidelines

Make Yourself Easy to See

Make yourself more visible, especially at night, by wearing bright reflective clothing, positioning yourself so other drivers can see you, signaling before turning or changing lanes, and using your horn when necessary.

Ride within Your Limits

Never ride beyond your personal abilities or faster than conditions warrant. Fatigue and inattention can impair your ability to use good judgement and ride safely.

Don't Drink or Use Drugs and Ride

Alcohol or drugs and riding don't mix. Even one alcoholic drink can reduce your ability to respond to changing conditions, and your reaction time gets worse with every additional drink. The same is true for drug use. Don't drink or use drugs and ride, and don't let your friends do it either.

Keep Your Honda in Safe Condition

It's important to keep your vehicle properly maintained and in safe riding condition. Inspect your vehicle before every ride and perform all recommended maintenance. Never exceed load limits (➤P. 13), and do not modify your vehicle or install accessories that would make your vehicle unsafe (➤P. 12).

If You are Involved in a Crash

Personal safety is your first priority. If you or anyone else has been injured, take time to assess the severity of the injuries and whether it is safe to continue riding. Call for emergency assistance if needed. Also follow applicable laws and regulations if another person or vehicle is involved in the crash.

SCV110S ID

If you decide to continue riding, first turn the ignition switch to the OFF position, and evaluate the condition of your vehicle.

SCV110S IID

If you decide to continue riding, first turn the ignition switch to the **O** (Off) position, and evaluate the condition of your vehicle.

Inspect for fluid leaks, check the tightness of critical nuts and bolts, and check the handlebar, control levers, brakes, and wheels. Ride slowly and cautiously.

Your vehicle may have suffered damage that is not immediately apparent. Have your vehicle thoroughly checked at a qualified service facility as soon as possible.

Carbon Monoxide Hazard

Exhaust contains poisonous carbon monoxide, a colourless, odorless gas. Breathing carbon monoxide can cause loss of consciousness and may lead to death.

If you run the engine in a confined or even partly enclosed area, the air you breathe could contain a dangerous amount of carbon monoxide.

Never run your vehicle inside a garage or other enclosure.

 WARNING

Running the engine of your vehicle while in an enclosed or even partially enclosed area can cause a rapid build-up of toxic carbon monoxide gas.

Breathing this colourless, odorless gas can quickly cause unconsciousness and lead to death.

Only run your vehicle's engine when it is located in a well ventilated area outdoors.

Image Labels

The following pages describe the label meanings. Some labels warn you of potential hazards that could cause serious injury. Others provide important safety information. Read this information carefully and don't remove the labels.

If a label comes off or becomes hard to read, contact your dealer for a replacement.

There is a specific symbol on each label. The meanings of each symbol and label are as follows.



Read instructions contained in Owner's Manual carefully.



Read instructions contained in Shop Manual carefully. In the interest of safety, take the vehicle to be serviced only by your dealer.



DANGER (with RED background)

You **WILL** be **KILLED** or **SERIOUSLY HURT** if you don't follow instructions.

WARNING (with ORANGE background)

You **CAN** be **KILLED** or **SERIOUSLY HURT** if you don't follow instructions.

CAUTION (with YELLOW background)

You **CAN** be **HURT** if you don't follow instructions.

**BATTERY LABEL****DANGER**

- Keep flame and spark away from the battery. Battery produce explosive gas that can cause explosion.
- Wear the eye protection and rubber gloves when handling the battery, or you can get burned or lose your eyesight by the battery electrolyte.
- Do not allow children and other people to touch a battery unless they understand proper handling and hazards of the battery very well.
- Handle the battery electrolyte with extreme care as it contains dilute sulfuric acid. Contact with your skin or eyes can burn you or cause loss of your eyesight.
- Read this manual carefully and understand it before handling the battery. Neglect of the instructions can cause personal injury and damage to the vehicle.
- Do not use a battery with the electrolyte at or below the lower level mark. It can explode causing serious injury.

**FUEL LABEL**

- Unleaded petrol only.
- This mark means that the vehicle parts are compliant up to 20% Ethanol blending with petrol.

Safety Precautions

Safety Precautions

- Ride cautiously and keep your hands on the handlebar and feet on the floor.
- Instruct your passenger to keep their hands on the grab rail or your waist and their feet on the footpegs while riding.
- Always consider the safety of your passenger, as well as other drivers and riders.

Protective Apparel

Make sure that you and any passenger are wearing an approved helmet, eye protection, and high-visibility protective clothing. Be sure to avoid loose clothes that could get caught on any part of your vehicle. Ride defensively in response to weather and road conditions.

I Helmet

Safety-standard certified, high-visibility, correct size for your head

- Must fit comfortably but securely, with the chin strap fastened

- Face shield with unobstructed field of vision or other approved eye protection

WARNING

Not wearing a helmet increases the chance of serious injury or death in a crash.

Make sure that you and any passenger always wear an approved helmet and protective apparel.

I Gloves

Full-finger leather gloves with high abrasion resistance

I Boots or Riding Shoes

Sturdy boots with non-slip soles and ankle protection

I Jacket and Trousers

Protective, highly visible, long-sleeved jacket and durable trousers for riding (or a protective suit)

Riding Precautions

Running-in Period

During the first 500 km (300 miles) of running, follow these guidelines to ensure your vehicle's future reliability and performance.

- Avoid full-throttle starts and rapid acceleration.
- Avoid hard braking.
- Ride conservatively.

Brakes

Observe the following guidelines:

- Avoid excessively hard braking.
 - ▶ Sudden braking can reduce the vehicle's stability.
 - ▶ Where possible, reduce speed before turning; otherwise you risk sliding out.
- Exercise caution on low traction surfaces.
 - ▶ The tyres slip more easily on such surfaces and braking distances are longer.
- Avoid continuous braking.

- ▶ Repeated braking, such as when descending long, steep slopes can seriously overheat the brakes, reducing their effectiveness.

- For full braking effectiveness, operate both the front and rear brakes together.

Combi Brake

Your vehicle is equipped with a brake system that distributes the braking force between the front and rear brakes.

The distribution of the braking force applied to the front and rear brakes when operating the front brake lever only and when operating the rear brake lever only is different.

For full braking effectiveness, operate both the front and rear brakes together.

Wet or Rainy Conditions

Road surfaces are slippery when wet, and wet brakes further reduce braking efficiency. Exercise extra caution when braking in wet conditions.

Riding Precautions

If the brakes get wet, apply the brakes while riding at low speed to help them dry.

Parking

- Park on a firm, level surface.
- If you must park on a slight incline or loose surface, park so that the vehicle cannot move or fall over.
- Make sure that high-temperature parts cannot come into contact with flammable materials.
- Do not touch the engine, muffler, brakes and other high-temperature parts until they cool down.

- **SCV110S ID**

To reduce the likelihood of theft, always lock the handlebar and remove the key and close the shutter when leaving the vehicle unattended.

SCV110S II ID

To reduce the likelihood of theft, always lock the handlebar, lock the ignition switch (➤P. 31) and leave your vehicle while taking the Honda SMART Key with you. Deactivate the Honda SMART Key system if necessary.

➤P. 26

Use of an anti-theft device is also recommended.

I Parking with the Centre Stand

1. Stop the engine.
2. To lower the centre stand, stand on the left side of the vehicle.
Hold the left handle grip and the grab rail.
Press down on the tip of the centre stand with your right foot and, simultaneously, pull up and back.

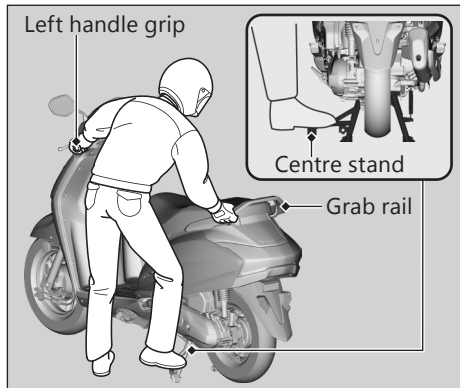

3. Turn the handlebar fully to the left.

4. SCV110S ID

Turn the ignition switch to the LOCK position (➔P. 22), remove the key and close the shutter (➔P. 24).

SCV110S II ID

Turn the ignition switch to the  (Lock) position (➔P. 22) and lock the ignition switch (➔P. 31).

Refuelling and Fuel Guidelines

Follow these guidelines to protect the engine, fuel system and catalytic converter:

- Use only unleaded petrol.
- Use the recommended octane number. Using lower octane petrol will result in decreased engine performance.
- Do not use fuels containing a high concentration of alcohol. ➔P. 120
- Do not use stale or contaminated petrol or an oil/petrol mixture.
- Avoid getting dirt or water in the fuel tank.

Accessories & Modifications

We strongly advise that you do not add any accessories that were not specifically designed for your vehicle by Honda or make modifications to your vehicle from its original design. Doing so can make it unsafe.

Modifying your vehicle may also void your warranty and make your vehicle illegal to operate on public roads. Before deciding to install accessories on your vehicle, be certain the modification is safe and legal.

WARNING

Improper accessories or modifications can cause a crash in which you can be seriously hurt or killed.

Follow all instructions in this owner's manual regarding accessories and modifications.

Do not pull a trailer with, or attach a sidecar to, your vehicle. Your vehicle was not designed for these attachments, and their use can seriously impair your vehicle's handling.

Loading

- Carrying extra weight affects your vehicle's handling, braking and stability.
Always ride at a safe speed for the load you are carrying.
- Avoid carrying an excessive load and keep within specified load limits.
Maximum weight capacity / Maximum luggage weight 📖 P. 122
- Tie all luggage securely, evenly balanced, and close to the centre of the vehicle.
- Do not place objects near the lights or the muffler.

WARNING

Overloading or improper loading can cause a crash and you can be seriously hurt or killed.

Follow all load limits and other loading guidelines in this manual.







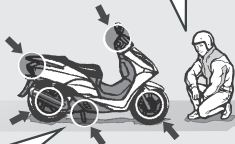

Basic Operation Flow

Pre-ride Inspection P. 55

Carefully inspect your vehicle to make sure that it is safe to ride.



How to use basic features.

- Instruments  P. 18
- Indicators  P. 19
- Switches  P. 20
- Steering Lock  P. 22
- **SCV110S ID**
Shutter  P. 24
- **SCV110S II ID** Honda SMART
Key System  P. 25
- **SCV110S II ID**
Answer Back System  P. 34
- Rear Brake Lock  P. 36

Acceleration P. 42

Apply throttle gradually.
Obey the speed limit.



Starting the Engine P. 37

Start and warm the engine.
Avoid revving the engine.



Starting the Vehicle P. 42

Before pulling away, indicate your direction with the turn signal switch, and check for oncoming traffic.



| Braking P. 43

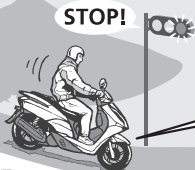

Close the throttle and apply the front and rear brakes together.

- ▶ The brakelight will indicate that you have applied the brakes.

| Stopping

If pulling off the road, signal early enough to show traffic that you are pulling over, and pull over smoothly.



| Turning Corners

Do your braking before entering corners.

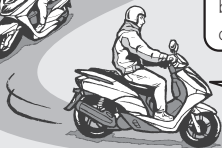

Gradually reapply throttle when exiting turn.

| Parking P. 10

Park on a firm level surface. Use the stand, set the parking brake, lock the steering.

SCV110S ID Close the shutter.



| Refuelling P. 44



Parts Location

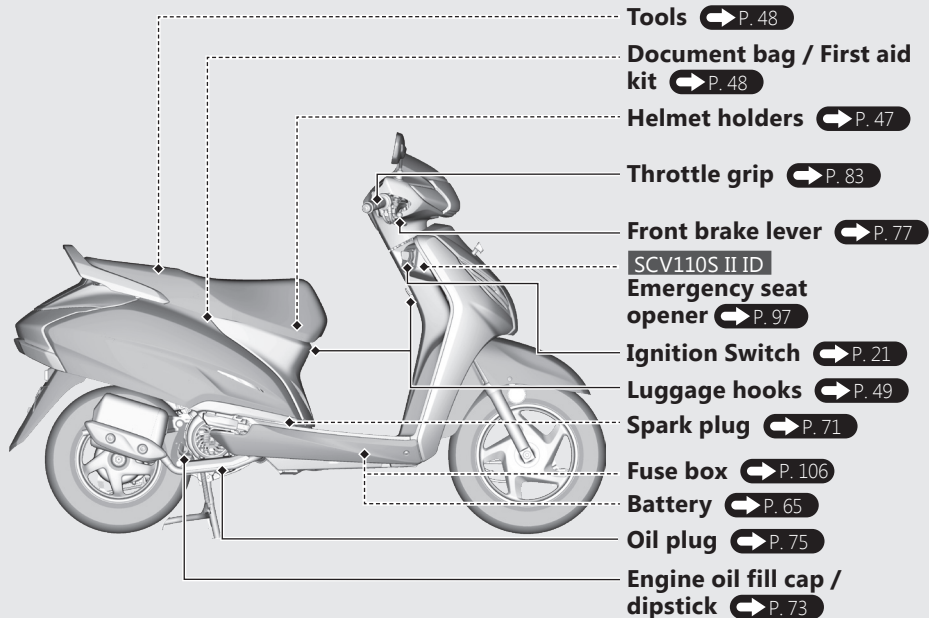

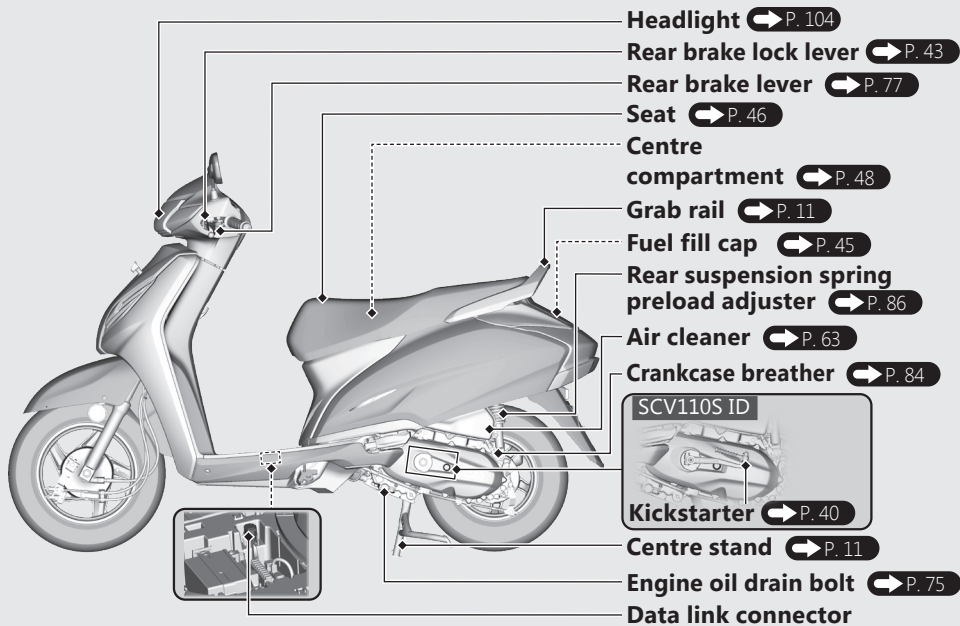

Instruments

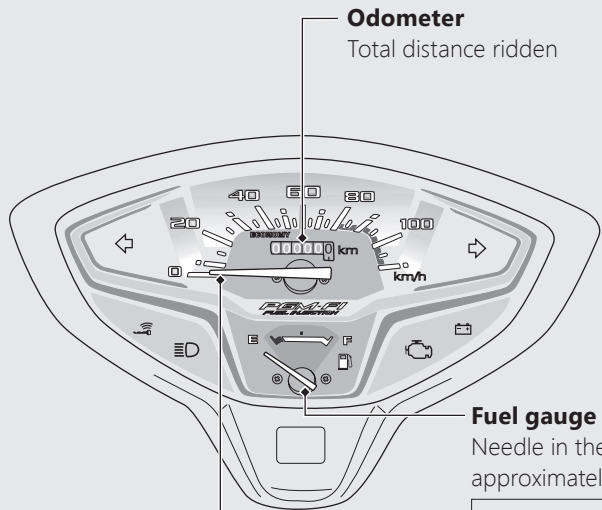

Odometer

Total distance ridden

Fuel gauge

Needle in the red mark, remaining fuel approximately: 1.2 L (0.32 US gal, 0.26 Imp gal)

Speedometer

This shows riding speed in kilometer per hour (km/h)

NOTICE

You should refuel when the reading approaches the red mark. Running out of fuel can cause the engine to misfire, damaging the catalytic converter.

Indicators

If one of these indicators does not come on when it should, have your dealer check for problems.

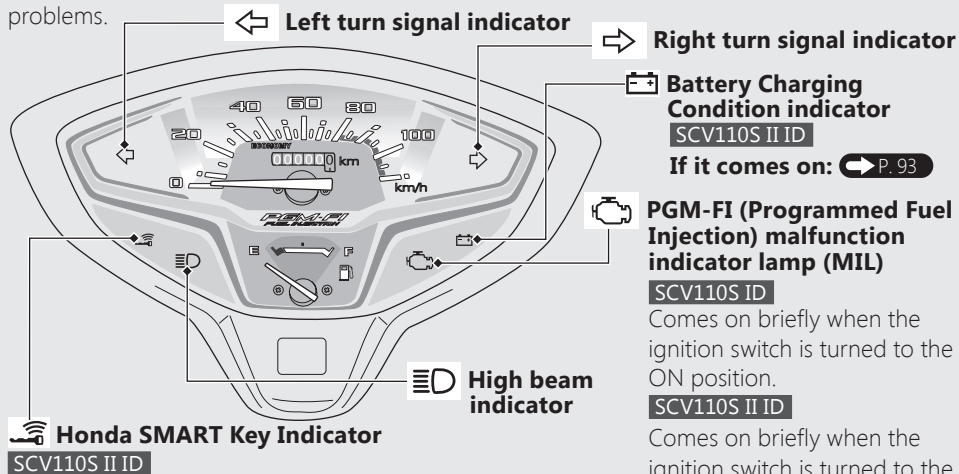

Comes on when vehicle and Honda SMART Key verification is complete, and the ignition switch can be operated. Goes off when the ignition switch is turned to the **I** (On) position.

When the Honda SMART Key Indicator Flashes: P. 93

Right turn signal indicator

Battery Charging Condition indicator
SCV110S II ID

If it comes on: P. 93

PGM-FI (Programmed Fuel Injection) malfunction indicator lamp (MIL)
SCV110S ID

Comes on briefly when the ignition switch is turned to the ON position.

SCV110S II ID

Comes on briefly when the ignition switch is turned to the **I** (On) position.

If it comes on while engine is running: P. 92

Switches

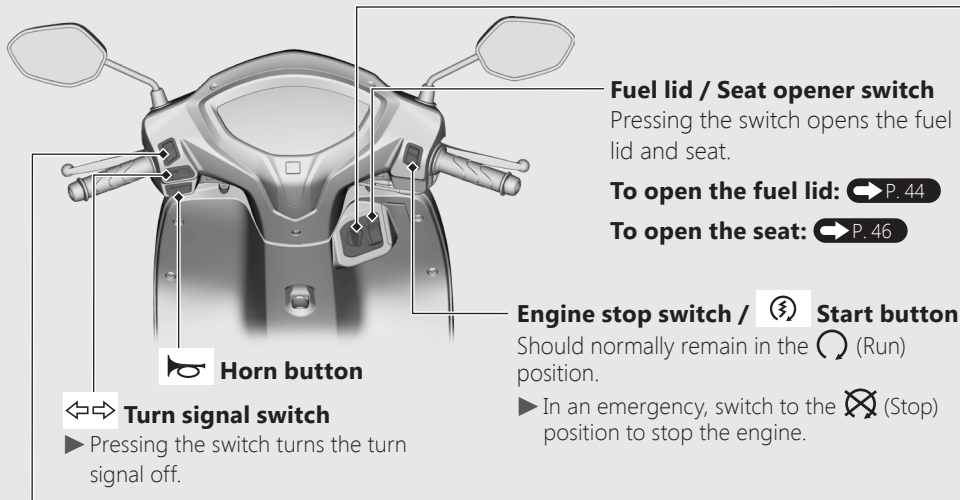

 **Horn button**

 **Turn signal switch**

▶ Pressing the switch turns the turn signal off.

Fuel lid / Seat opener switch

Pressing the switch opens the fuel lid and seat.

To open the fuel lid:  P. 44



To open the seat:  P. 46

Engine stop switch /  Start button

Should normally remain in the  (Run) position.

▶ In an emergency, switch to the  (Stop) position to stop the engine.

Headlight dimmer / Passing light control switch

-  **H**: High beam
-  **L**: Low beam
-  **PASS**: Flashes the high beam headlight.

Ignition switch

Switches the electrical system on/off, locks the steering, and operates the fuel lid and seat opener switch.

SCV110S ID

► Key can be removed when in the OFF or LOCK position.

SCV110S II ID

► To unlock the ignition switch.  P. 30

SCV110S ID

ON

Turns electrical system on for starting/riding.

FUEL SEAT

Operates the seat/fuel lid opener switch.

OFF

Turns engine off.

LOCK

Locks steering.

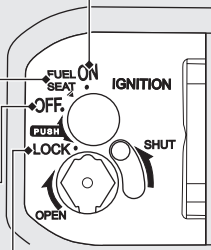

SCV110S II ID

ON

Turns electrical system on for starting/riding.

LOCK

Locks steering.

OFF

Turns engine off.

SEAT FUEL

Operates the seat/fuel lid opener switch.

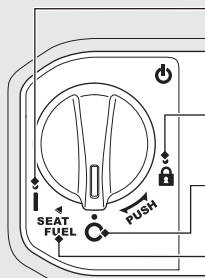

Switches (Continued)

Steering Lock

Lock the steering when parking to help prevent theft.

A U-shaped wheel lock or similar device is also recommended.

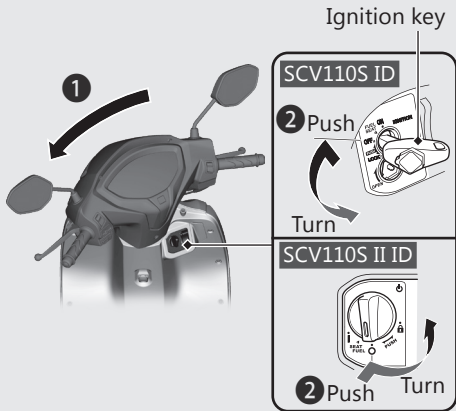

Locking

1 Turn the handlebar all the way to the left.

2 **SCV110S ID**

Push the key down, and turn the ignition switch to the LOCK position.

▶ Jiggle the handlebar if the lock is difficult to engage.

SCV110S II ID

Push the ignition switch down, and turn it to the  (Lock) position.

▶ Jiggle the handlebar if the lock is difficult to engage.

▶ To unlock the ignition switch  P. 30

3 **SCV110S ID**

Remove the key.

SCV110S II ID

Lock the ignition switch.  P. 31

Unlocking

SCV110S ID

Insert the key, push it in, and turn the ignition switch to the OFF position.

SCV110S II ID

Push the ignition switch in, and turn it to the  (Off) position.

▶ To unlock the ignition switch  P. 30

Switches (Continued)

Shutter

SCV110S ID

The ignition switch for this vehicle is equipped with a shutter. After parking the vehicle, close the shutter for theft prevention.

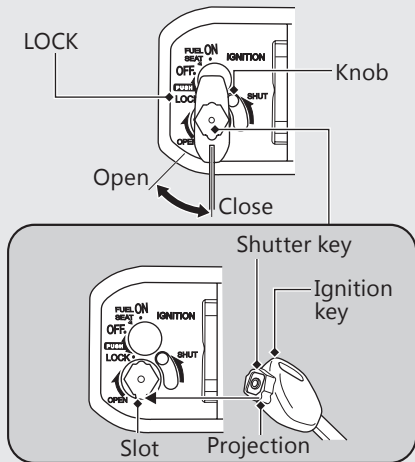

Close

- 1 Remove the ignition key from the ignition switch.
- 2 Align the projection of the shutter key with the slot of the shutter, and turn the shutter key counterclockwise.
 - ▶ You can also close the shutter by moving the knob upward without the shutter key.
- 3 Remove the key.

Open

Align the projection of the shutter key with the slot of the shutter, and turn the shutter key clockwise.

Honda SMART Key System

SCV110S II ID

The Honda SMART Key system allows you to operate the main switch without inserting a key into a keyhole.

The system runs a two-way authentication between the vehicle and the Honda SMART Key to verify if it is the registered Honda SMART Key.

The Honda SMART Key system uses lowintensity radio waves. It may affect medical equipment such as a cardiac pacemaker.

Honda SMART Key System *(Continued)*

Switching the Honda SMART Key System

| To switch the Honda SMART Key system to activation or deactivation

Push and hold the ON/OFF button until the Honda SMART Key LED changes colour.

| To check the Honda SMART Key system status

Lightly press the ON/OFF button. The Honda SMART Key LED will show the status. When the Honda SMART Key LED is:

- Green: Honda SMART Key system authentication can be performed.
- Red: Honda SMART Key system authentication cannot be performed.

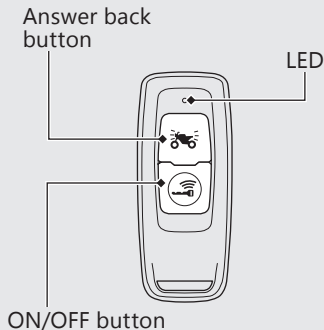

Operating Range

The operating range varies when the ignition switch is locked or unlocked.

The Honda SMART Key system uses low-intensity radio waves. Therefore, the operating range may be wider or narrower, or the Honda SMART Key system may not work properly in the following situations:

- When the Honda SMART Key battery is depleted.
- When there are facilities nearby that generate strong radio waves or noise, such as TV towers, power stations, radio stations, or airports.
- When you carry the Honda SMART Key with a laptop or wireless communication device such as a radio or mobile phone.
- When the Honda SMART Key comes into contact with or is covered by metal objects.

When the ignition switch is unlocked:

The system can be operated within the shaded area shown in the illustration.

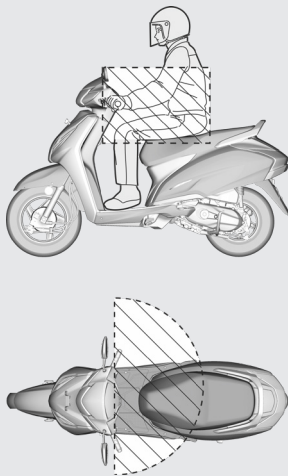

Honda SMART Key System *(Continued)*

When the ignition switch is locked:

The system can be operated within the shaded area shown in the illustration.

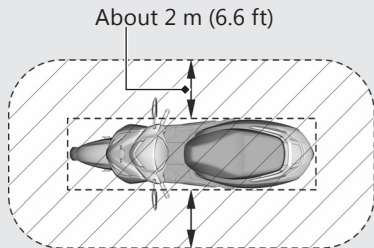

Anyone can unlock the ignition switch and start the engine if your Honda SMART Key is within operating range of your vehicle, even if you are on the other side of a wall or window. If you are away from your vehicle but your Honda SMART Key is still within operating range, deactivate the Honda SMART Key system.

To switching the Honda SMART Key system ➔ P. 26

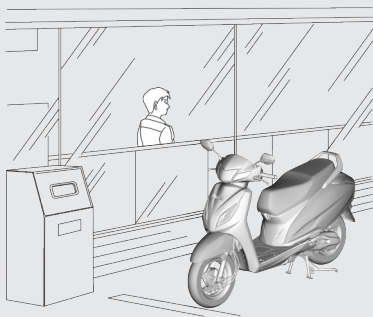

Anyone in possession of the Honda SMART Key can perform the following operations if the Honda SMART Key is within operating range:

- Starting the engine
- Unlocking the ignition switch
- Unlocking the seat lock
- Unlocking the fuel fill cap
- Unlocking the steering lock

You should always keep the Honda SMART Key on your person after you get on and off the vehicle or while riding.

Do not place the Honda SMART Key in any compartment.

If the ignition switch is in the **I** (On) position, the vehicle can be operated even by a person who does not have a verified Honda SMART Key.

Whenever you leave your vehicle, lock the steering and lock the ignition switch.

 P. 31

Make sure all the turn signals flash once.



Honda SMART Key System *(Continued)*

Switching the ignition switch

| To Unlock the Ignition Switch





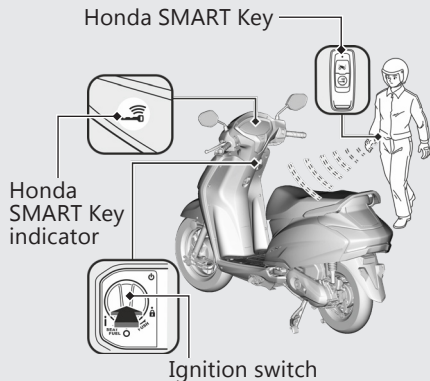

- 1 Make sure that the Honda SMART Key system is activated.  P. 26
- 2 To authenticate the Honda SMART Key system, push the ignition switch.
 - ▶ When properly authenticated and the ignition switch is unlocked, the Honda SMART Key indicator comes on.
- 3 Turn the ignition switch to the **|** (On) position while the Honda SMART Key indicator comes on.
 - ▶ If you do not turn the ignition switch to the **|** (On) position within 20 seconds after pushing the ignition switch, the Honda SMART Key indicator will go off, the turn signals flash once, and then the ignition switch will be locked.

When the Honda SMART Key system does not work properly  P. 95

If someone without the Honda SMART Key tries to turn the ignition switch, the ignition switch rotates freely. If you notice the ignition switch is in a different position, turn the ignition switch to the original  (Off) or  (Lock) position.



To Lock the Ignition Switch



- 1 Turn the ignition switch to the SEAT FUEL,  (Off) or  (Lock) position.
- 2 Lock the ignition switch by doing one of the following:
 - Leave the operating range with the Honda SMART Key.  P. 27
 - Push the ignition switch and release within 200 milliseconds.
 - Wait for approximately 20 seconds after turning the ignition switch from  (On) to SEAT FUEL,  (Off) or  (Lock) position.
 - Switch the Honda SMART Key system to inactive.  P. 26

Honda SMART Key System (Continued)

- 3 Make sure that the Honda SMART Key indicator goes off, the turn signals flash once. This indicates that the ignition switch is locked.

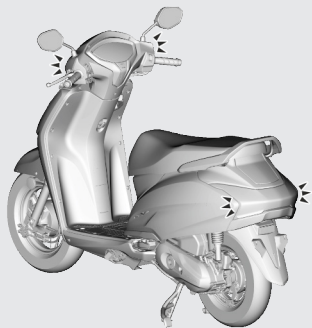
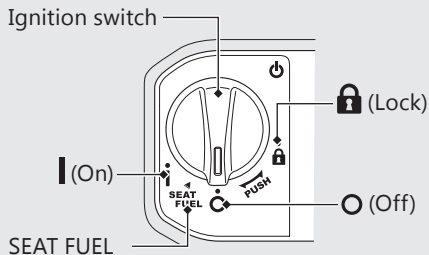
When the Honda SMART Key system does not work properly  P. 95



Always make sure the ignition switch position is in the  (Off) or  (Lock) position when you leave your vehicle.



When the ignition switch is locked in the SEAT FUEL position, the ignition switch can be turned to the  (Off) position only once.

When the ignition switch is locked in the  (Off) position, the steering cannot be locked. To lock the steering, unlock the ignition switch.

Answer Back System

SCV110S II ID

The answer back system is a device to find the location of your vehicle.

When the immobilizer is active and you press the answer back button on the Honda SMART Key with the ignition switch in the SEAT FUEL,  (Off) or  (Lock) position, the turn signals light informing you of your vehicle's location.

The answer back system uses low-intensity radio waves. It may affect medical equipment such as a cardiac pacemaker.

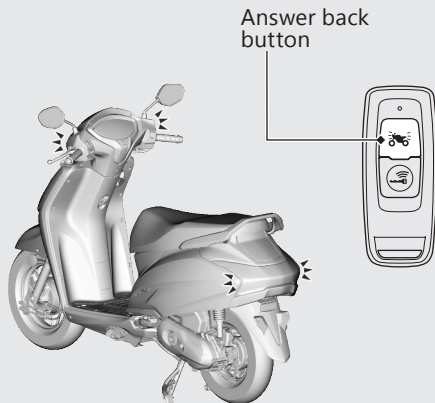

Operation

Press the answer back button on the Honda SMART Key.

- ▶ The answer back system will not function when the ignition switch is in the **I** (On) position.

If the ignition switch is left in the **O** (Off) or **A** (Lock) position for more than 10 days, the answer back system will no longer operate. When the system is active and the vehicle receives a signal from pressing answer back button, system activation will be extended for 10 days. To reset the system, turn the ignition switch to the **I** (On) position once.

- ▶ To unlock the ignition switch  P. 30

When the battery in the vehicle is weak, the answer back system may not function.

Rear Brake Lock

Be sure the rear brake lock is applied while starting and warming up the engine.

Locking

Squeeze the rear brake lever and set the rear brake lock lever.

- ▶ The rear brake lock will not function if the rear brake is not adjusted properly.  P. 77

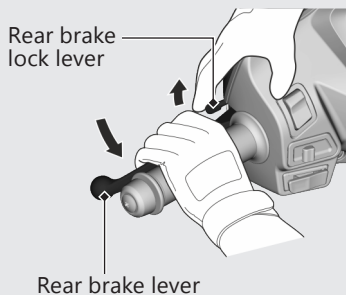

Unlocking

Squeeze the rear brake lever.

- ▶ Before riding, make sure that the rear brake lock is fully released so there is no drag on the rear wheel.

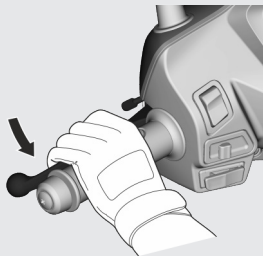

Starting the Engine

Start your engine using the following procedure, regardless of whether the engine is cold or warm.

SCV110S II ID

This vehicle is equipped with a Honda SMART Key system. Always keep Honda SMART Key on you when you ride the vehicle.  P. 27

If the engine of this vehicle is stopped while the ignition switch is in the **I** (On) position, authentication will be disabled after a certain amount of time or if you leave the authentication range. Restart the engine by performing step **3** & **4** under the starting procedure.

NOTICE

- **SCV110S ID** If the engine does not start within 5 seconds, turn the ignition switch to the OFF position and wait 10 seconds before trying to start the engine again to recover battery voltage.
- **SCV110S II ID** If the engine does not start within 5 seconds, turn the ignition switch to the **O** (Off) position and wait 10 seconds before trying to start the engine again to recover battery voltage.
- Extended fast idling and rewing the engine can damage the engine and the exhaust system.
- **SCV110S ID** Do not operate the kickstarter while the engine is running as engine damage could result. Do not apply excessive force on the kickstarter.
- **SCV110S ID** Fold up the kickstarter after the kickstarter is returned to the pedal stop.

Starting the Engine *(Continued)*

1 Place the vehicle on its centre stand.

2 **SCV110S ID**

Turn the ignition switch to the ON position.

SCV110S II ID

Turn the ignition switch to the **I** (On) position.

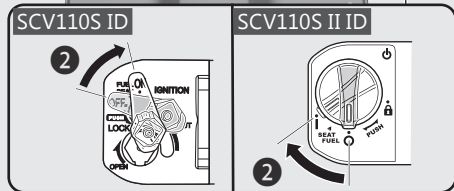
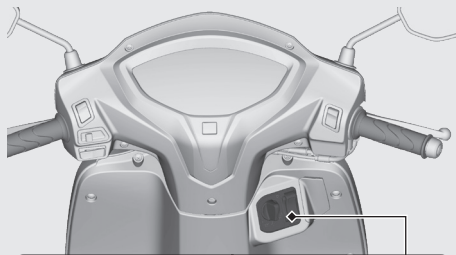

- 3** Squeeze the rear brake lever.
- ▶ The starter motor will only work when the brake lever is squeezed.

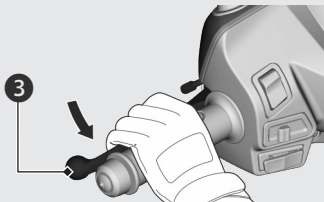

To Start the Engine with Electric Starter

- 4** With the throttle closed, press the start button.
- Release the start button as soon as the engine starts

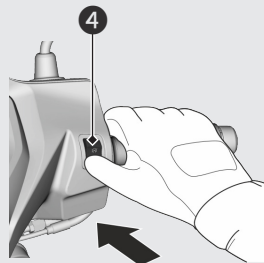

Starting the Engine (Continued)

To Start the Engine with Kickstarter

SCV110S ID

- 4 With the throttle completely closed, operate the kickstarter starting from the top of the stroke, kick through to the bottom with a rapid, continuous motion.

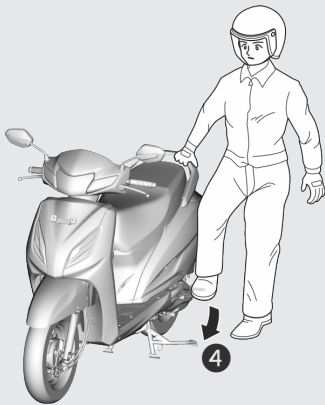

If you cannot start the engine:

Open the throttle slightly (about 3 mm, without freeplay) while starting the engine.

About 3 mm, without freeplay

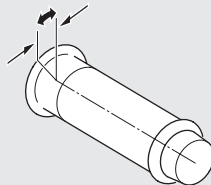

If the engine does not start: Using the start button

- ① Open the throttle fully and press the start button for 5 seconds.
- ② Follow the normal starting procedure.
- ③ If the engine starts with unstable idle, open the throttle slightly.
- ④ If the engine does not start, wait 10 seconds before trying steps ① - ③ again.

Using the kickstarter

SCV110S ID

- ① Turn off the ignition switch.
- ② Open the throttle fully.
- ③ Crank the engine several times with the kickstarter.
- ④ Follow the normal starting procedure.
- ⑤ If the engine starts with unstable idle, open the throttle slightly.

| If Engine Will Not Start ➔ P. 91

Riding

Starting the vehicle

- 1 Push the vehicle forward off the centre stand.
 - ▶ Lock the rear brake lock.
 - ▶ Keep throttle closed.
- 2 Get on the vehicle.
 - ▶ Mount the vehicle from the left side, keeping at least one foot on the ground.
- 3 Release the rear brake lock

- 4 Acceleration and deceleration
To accelerate: Open the throttle slowly.
To decelerate: Close the throttle.

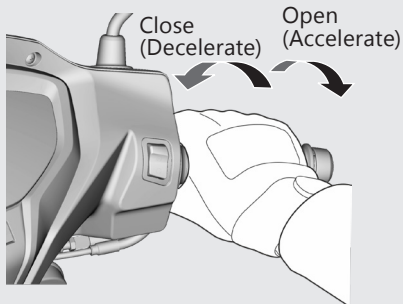

Braking

Close the throttle and apply the front and rear brake levers together.

Do not apply the brake lock while riding. It may cause the wheel to lock, reducing control of the vehicle.

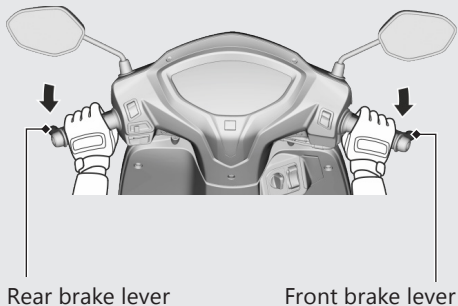

Refuelling

Do not fill with fuel above the lower edge of the filler neck.

Fuel type: Unleaded petrol only

Fuel octane number: Your vehicle is designed to use Research Octane Number (RON) 91 or higher.

Tank capacity: 5.3 litres (1.4 US gal, 1.17 Imp gal)

Refuelling and Fuel Guidelines ➔ P. 11

Opening the Fuel Fill Cap

1 SCV110S ID

Insert the ignition key and turn it to the FUEL SEAT position.

SCV110S II ID

Turn the ignition switch to the SEAT FUEL position.

▶ To unlock the ignition switch ➔ P. 30

2 Press the FUEL side of the fuel lid / seat opener switch.

▶ The fuel lid opens.

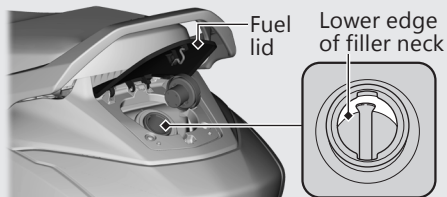
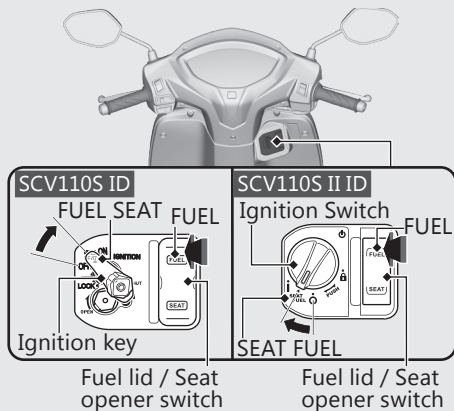

- 3 Turn the fuel fill cap counterclockwise until it stops and remove the cap.

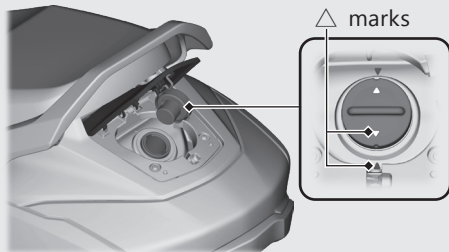
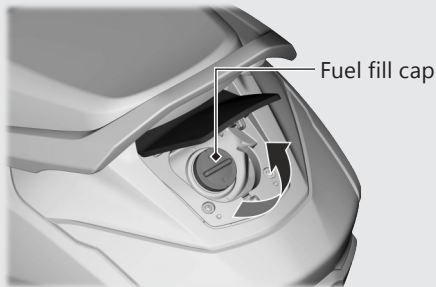

Closing the Fuel Fill Cap

- 1 Install and tighten the fuel fill cap firmly by turning it clockwise.
 - ▶ Make sure that the \triangle marks on the fuel fill cap and fuel tank are aligned.
- 2 Close and push down the fuel lid until it locks.

⚠WARNING

Petrol is highly flammable and explosive. You can be burned or seriously injured when handling fuel.

- Stop the engine, and keep heat, sparks, and flames away.
- Only handle fuel outdoors.
- Wipe up spills immediately.

Storage Equipment

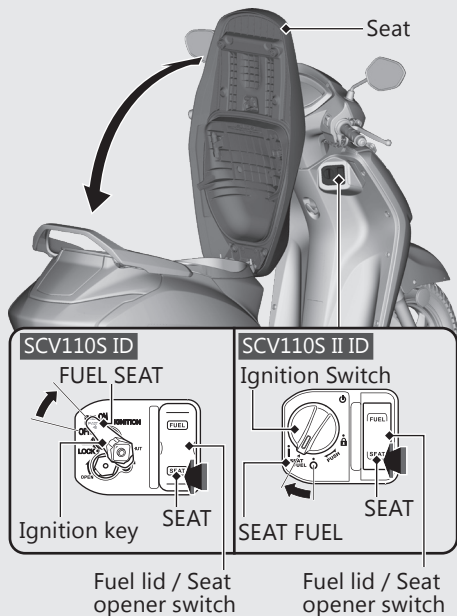

Seat Open

1 SCV110S ID

Insert the ignition key and turn it to the FUEL SEAT position.

▶ To unlock the shutter and steering lock

➡ P. 24 , ➡ P. 23

SCV110S II ID

Turn the ignition switch to the SEAT FUEL position.

▶ To unlock the ignition switch ➡ P. 30

- 2 Turn the handlebar pointed straight ahead.
- 3 Press the SEAT side of the fuel lid / seat opener switch.
- 4 Open the seat.

Seat Close

Close and push down on the rear of the seat until locks. Make sure that the seat is locked securely to pull it up lightly.

Take care not to lock your key in the centre compartment under the seat.

Helmet Holders

The helmet holders are located under the seat.

- ▶ Use the helmet holder only when parked.

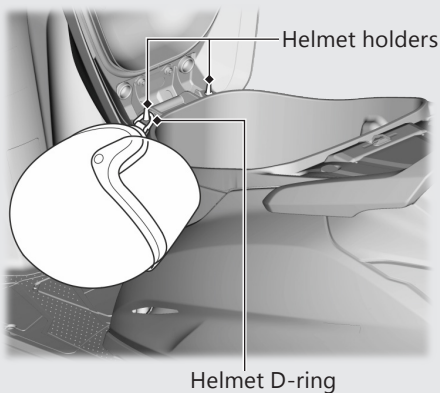

⚠ WARNING

Riding with a helmet attached to the holder can interfere with your ability to safely operate the vehicle and could lead to a crash in which you can be seriously hurt or killed.

Use the helmet holder only while parked. Do not ride with a helmet secured by the holder.

Storage Equipment *(Continued)*

Tools

Tools are stored in the reverse side of the seat.

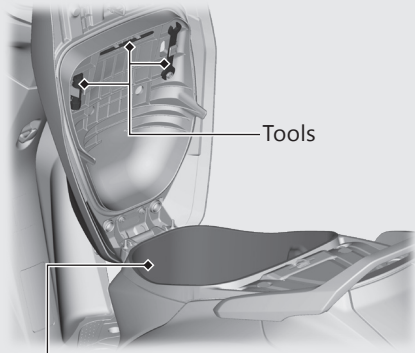

Centre compartment

Never exceed the maximum weight limit.

Maximum Weight: 10 kg (22 lbs)

- ▶ Do not store any items that are flammable or susceptible to heat damage.
- ▶ Do not store valuables or fragile articles.

Document Bag/ First Aid Kit

Document bag and first aid kit are located in the centre compartment.

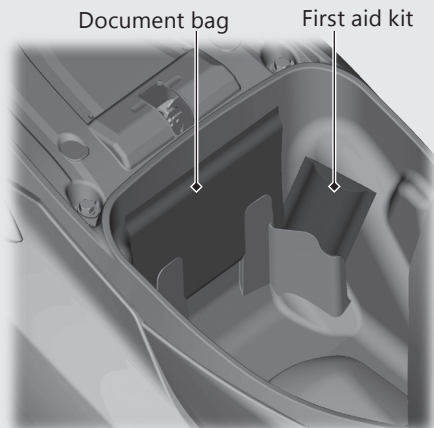

Luggage Hooks

The luggage hooks are provided below the handlebar and the seat.

- ▶ Do not attach large luggage to the hook that would hang out from the vehicle and/or interfere with the movement of your feet and handle operation.

Never exceed the maximum weight limit.

Maximum Weight: 1.5 kg (3 lbs)

Luggage hooks

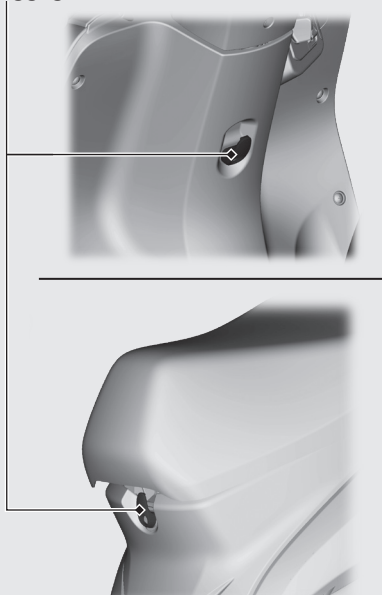

Maintenance

Please read “Importance of Maintenance” and “Maintenance Fundamentals” carefully before attempting any maintenance. Refer to “Specifications” for service data.

Importance of Maintenance	P. 51	Spark Plug	P. 71
Maintenance Schedule	P. 52	Engine Oil	P. 73
Maintenance Fundamentals	P. 55	Brakes	P. 77
Tools	P. 64	Throttle	P. 83
Removing & Installing Body Components	P. 65	Crankcase Breather	P. 84
Battery.....	P. 65	Other Adjustments	P. 85
Battery Lid.....	P. 66	Adjusting the Headlight Aim.....	P. 85
Body Cover.....	P. 67	Adjusting the Rear Suspension.....	P. 86
Clip.....	P. 68	Other Replacement	P. 87
Headlight Case.....	P. 69	Replacing the Honda SMART Key Battery.....	P. 87

Importance of Maintenance

Importance of Maintenance

Keeping your vehicle well-maintained is absolutely essential to your safety and to protect your investment, obtain maximum performance, avoid breakdowns, and reduce air pollution. Maintenance is the owner's responsibility. Be sure to inspect your vehicle before each ride and perform the periodic checks specified in the Maintenance Schedule. ➔ P. 52

WARNING

Improperly maintaining your vehicle or failing to correct a problem before you ride can cause a crash in which you can be seriously hurt or killed.

Always follow the inspection and maintenance recommendations and schedules in this owner's manual.

Maintenance Safety

Always read the maintenance instructions before you begin each task and make sure that you have the tools, parts, and skills required. We cannot warn you of every conceivable hazard that can arise in performing maintenance. Only you can decide whether or not you should perform a given task.

Follow these guidelines when performing maintenance.

- **SCV110S ID**
Stop the engine and remove the key.
- **SCV110S II ID**
Stop the engine and turn the ignition switch to the  (Off) position.
- Place your vehicle on a firm, level surface using the centre stand to provide support.
- Allow the engine, muffler, brakes, and other high-temperature parts to cool before servicing as you can get burned.
- Run the engine only when instructed, and do so in a well-ventilated area.

Maintenance Schedule

The maintenance schedule specifies the maintenance requirements necessary to ensure safe, dependable performance, and proper emission control.

Maintenance work should be performed in accordance with Honda's standards and specifications by properly trained and equipped technicians. Your dealer meets all of these requirements. Keep an accurate record of maintenance to help ensure that your vehicle is properly maintained. Make sure that whomever performs the maintenance completes this record.

All scheduled maintenance is considered a normal owner operating cost and will be charged to you by your dealer. Retain all receipts. If you sell the vehicle, these receipts should be transferred with the vehicle to the new owner.

Honda recommends that your dealer should road test your vehicle after each periodic maintenance is carried out.

Items	Pre-ride Check P. 55	Frequency *1								Annual Check	Regular Replace	Refer to page
		× 1,000 km	1	6	12	18	24	30	36			
		× 1,000 mile	0.6	4	8	12	16	20	24			
		Months	1	6	12	18	24	30	36			
Honda Diagnostic System				I		I		I				-
Fuel Line				I	I	I	I	I	I	I		-
Fuel Level		I										-
Throttle Operation		I		I	I	I	I	I	I	I		83
Air Cleaner *2						R				R		63
Crankcase Breather*3				C	C	C	C	C	C	C		84
Spark Plug				I	R	I	R	I	R			71
Valve Clearance				I	I	I	I	I	I			-
Engine Oil		I		R	R	R	R	R	R	R	R	73
Engine Oil Strainer Screen						C		C		C		74
Engine Idle Speed				I	I	I	I	I	I	I	I	-
Evaporative Emission Control System						I				I		-
Drive Belt					I			R		I		-
Final Drive Oil *4											2 Years	-











































































Maintenance Level

- : Intermediate. We recommend service by your dealer, unless you have the necessary tools and are mechanically skilled. Procedures are provided in an official Honda Shop Manual.
- : Technical. In the interest of safety, have your vehicle serviced by your dealer.

Maintenance Legend

- I** : Inspect (clean, adjust, lubricate, or replace, if necessary)
- R** : Replace
- C** : Clean

Maintenance Schedule

Items	Pre-ride Check  P. 55	Frequency *1								Annual Check	Regular Replace	Refer to page
		× 1,000 km	1	6	12	18	24	30	36			
		× 1,000 mile	0.6	4	8	12	16	20	24			
Brake Shoes Wear												82
Brake System												77
Brake Lock Operation												36
Headlight Aim												85
Lights / Horn												-
Engine Stop Switch												20
Clutch Shoes Wear												-
Suspension												-
Nuts, Bolts, Fasteners												-
Wheels / Tires												61
Steering Head Bearings												-

Service according to odometer reading or months, whichever is earlier.

Notes:

- *1 : At higher odometer reading, repeat at the frequency interval established here.
- *2 : Service more frequently when riding in unusually wet or dusty areas.
- *3 : Service more frequently when riding in rain or at full throttle.
- *4 : Replacement requires mechanical skill.

Pre-ride Inspection

To ensure safety, it is your responsibility to perform a pre-ride inspection and make sure that any problem you find is corrected. A pre-ride inspection is a must, not only for safety, but because having a breakdown, or even a flat tyre, can be a major inconvenience.

Check the following items before you get on your vehicle:

- Fuel level - Fill fuel tank when necessary ➤P. 44
- Throttle - Check for smooth opening and full closing in all steering positions ➤P. 83
- Engine oil level - Add engine oil if necessary. Check for leaks ➤P. 73
- Brakes - Check operation;
Front and Rear: check shoes wear and freeplay, adjust if necessary ➤P. 82, 77

- Lights and horn - Check that lights, indicators and horn function properly
- Engine stop switch - Check for proper function ➤P. 20
- Wheels and tyres - Check condition, air pressure and adjust if necessary ➤P. 61

Replacing Parts

Always use Honda Genuine Parts or their equivalents to ensure reliability and safety.

WARNING

Installing non-Honda parts may make your vehicle unsafe and cause a crash in which you can be seriously hurt or killed.

Always use Honda Genuine Parts or equivalents that have been designed and approved for your vehicle.

Battery

Your vehicle has a maintenance-free type battery. You do not have to check the battery electrolyte level or add distilled water. Clean the battery terminals if they become dirty or corroded.

Do not remove the battery cap seals. There is no need to remove the cap when charging.

NOTICE

Your battery is a maintenance-free type and can be permanently damaged if the cap strip is removed.

NOTICE

An improperly disposed of battery can be harmful to the environment and human health. Always confirm local regulations for proper battery disposal instruction.

What to do in an emergency

If any of the following occur, immediately see your doctor.

- Electrolyte splashes into your eyes:
 - ▶ Wash your eyes repeatedly with cool water for at least 15 minutes. Using water under pressure can damage your eyes.
- Electrolyte splashes onto your skin:
 - ▶ Remove affected clothing and wash your skin thoroughly using water.
- Electrolyte splashes into your mouth:
 - ▶ Rinse mouth thoroughly with water, and do not swallow.

WARNING

The battery gives off explosive hydrogen gas during normal operation.

A spark or flame can cause the battery to explode with enough force to kill or seriously hurt you.

Wear protective clothing and a face shield, or have a skilled mechanic do the battery servicing.

Cleaning the Battery Terminals

1. Remove the battery. ➤ P. 65
2. If the terminals are starting to corrode and are coated with a white substance, wash with warm water and wipe clean.
3. If the terminals are heavily corroded, clean and polish the terminals with a wire brush or sandpaper. Wear safety glasses.

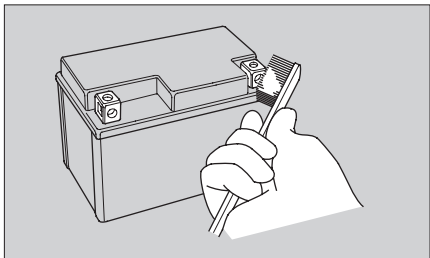

4. After cleaning, reinstall the battery.

The battery has a limited life span. Consult your dealer about when you should replace the battery. Always replace the battery with another maintenance-free battery of the same type.

NOTICE

Installing non-Honda electrical accessories can overload the electrical system, discharging the battery and possibly damaging the system.

Fuses

Fuses protect the electrical circuits on your vehicle. If something electrical on your vehicle stops working, check for and replace any blown fuses. ➤ P. 106

Inspecting and Replacing Fuses

SCV110S ID

Turn the ignition switch to the OFF position to remove and inspect fuses.

SCV110S II ID

Turn the ignition switch to the ○ (Off) position to remove and inspect fuses.

If a fuse is blown, replace with a fuse of the same rating. For fuse ratings, see "Specifications." ➤ P. 124

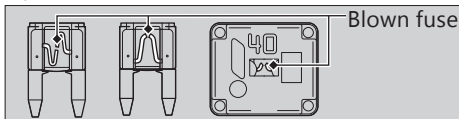

NOTICE

Replacing a fuse with one that has a higher rating greatly increases the chance of damage to the electrical system.

If a fuse fails repeatedly, you likely have an electrical fault. Have your vehicle inspected by your dealer.

Engine Oil

Engine oil consumption varies and oil quality deteriorates according to riding conditions and time elapsed.

Check the engine oil level regularly, and add the recommended engine oil if necessary. Dirty oil or old oil should be changed as soon as possible.

Selecting the Engine Oil

For recommended engine oil, see "Specifications." ➤ P. 123

If you wish to use other than recommended engine oil, check the label to make sure that the oil satisfies all of the following standards:

- JASO T 903 standard*¹: MB
- SAE standard*²: 10W-30
- API classification*³: SJ or higher

Maintenance Fundamentals

1. The JASO T 903 standard is an index for engine oils for 4-stroke motorcycle engines. There are two classes: MA and MB. For example, the following label shows the MB classification.

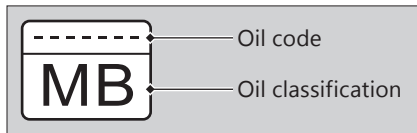

2. The SAE standard grades oils by their viscosity.
3. The API classification specifies the quality and performance rating of engine oils. Use SJ or higher oils, excluding oils marked as "Energy Conserving" or "Resource Conserving" on the circular API service symbol.

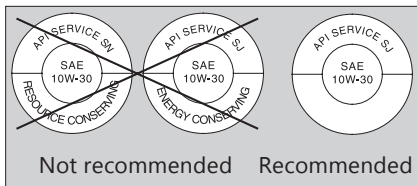

Crankcase Breather

Service more frequently when riding in rain, at full throttle, or after the vehicle is washed or overturned. Service if the deposit level can be seen in the transparent section of the drain tube.

If the drain tube overflows, the air filter may become contaminated with engine oil, causing poor engine performance. ➡ P. 84

Tyres (Inspecting/Replacing)

Checking the Air Pressure

Visually inspect your tyres and use an air pressure gauge to measure the air pressure at least once a month or any time you think the tyres look low. Always check air pressure when your tyres are cold.

Inspecting for Damage

Inspect the tyres for cuts, slits, or cracks that exposes fabric or cords, or nails or other foreign objects embedded in the side of the tyre or the tread. Also

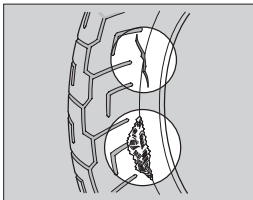

inspect for any unusual bumps or bulges in the side walls of the tyres.

Inspecting for Abnormal Wear

Inspect the tyres for signs of abnormal wear on the contact surface.

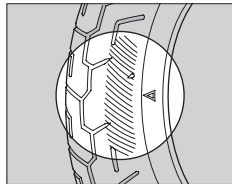

Inspecting Tread Depth

Inspect the tread wear indicators. If they become visible, replace the tyres immediately.

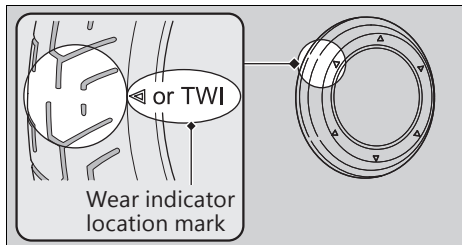

⚠️ WARNING

Riding on tyres that are excessively worn or improperly inflated can cause a crash in which you can be seriously hurt or killed.

Follow all instructions in this owner's manual regarding tyre inflation and maintenance.

Have your tyres replaced by your dealer. For recommended tyres and air pressure, see "Specifications." ➤ P. 123

Follow these guidelines whenever you replace tyres:

- Use the recommended tyres or their equivalents of the same size, construction, speed rating, and load range.

- Do not install a tube inside a tubeless tyre on this vehicle. Excessive heat build-up can cause the tube to burst.
- Use only tubeless tyres on this vehicle. The rims are designed for tubeless tyres, and during hard acceleration or braking, a tube-type tyre could slip on the rim and cause the tyre to rapidly deflate.

! WARNING

Installing improper tyres on your vehicle can adversely affect handling and stability, and can cause a crash in which you can be seriously hurt or killed.

Always use the size and type of tyres recommended in this owner's manual.

Air Cleaner

This vehicle is equipped with a viscous type air cleaner element.

Air blow cleaning or any other cleaning can degrade the viscous element performance and cause the intake of dust.

Do not perform the maintenance. Should be serviced by your dealer.

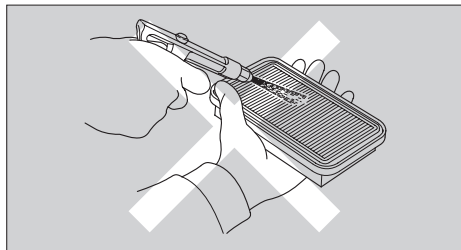

Tools

Tools are stored in the reverse side of the seat.

➔ P. 48

You can perform some roadside repairs, minor adjustments and parts replacement with the provided tools.

- Spark plug wrench
- 12 x 14 mm Open end wrench
- Standard / Philips Screwdriver

Battery

Removal

SCV110S ID

Make sure the ignition switch is in the OFF position.

SCV110S II ID

Make sure the ignition switch is in the **O** (Off) position.

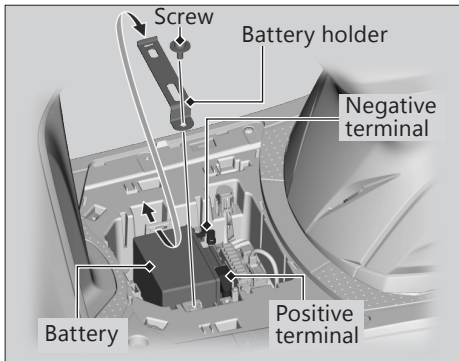

1. Remove the battery lid. ➔P. 66
2. Remove the battery holder by removing the screw.
3. Disconnect the negative \ominus terminal from the battery.
4. Disconnect the positive \oplus terminal from the battery.
5. Remove the battery, taking care not to drop the terminal nuts.

Installation

Install the parts in the reverse order of removal. Always connect the positive \oplus terminal first. Make sure bolts and nuts are tight.

For proper handling of the battery, see "Maintenance Fundamentals." ➔P. 56
"Battery Goes Dead." ➔P. 103

Battery Lid

Removal

Remove the screws and battery lid.

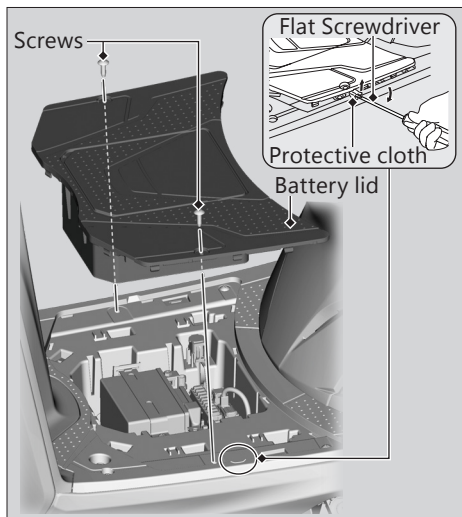

Installation

Install the parts in the reverse order of removal.

Body Cover

Lift-up

1. Open the seat. ► P. 46
2. Remove the bolts.
3. Remove the clips. ► P. 68
4. Lift-up the body cover and set the maintenance rod.

Installation

Install the parts in the reverse order of removal.

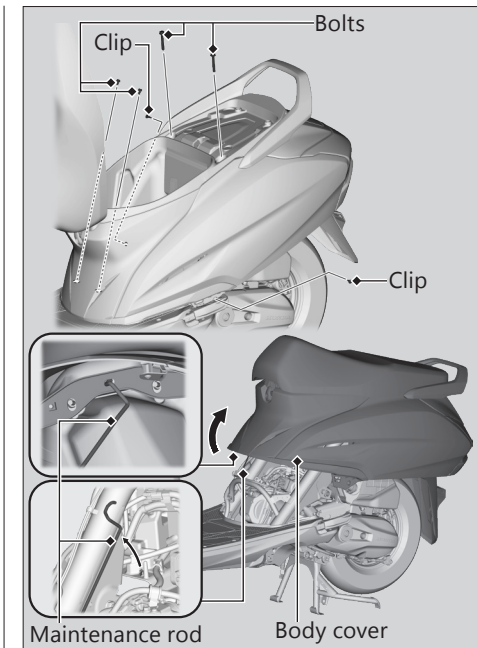

Clip

Removal :

1. Press down on the centre pin to release the lock.
2. Pull the clip out of the hole.

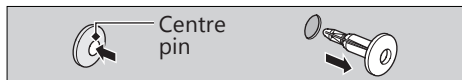

Installation :

1. Push the bottom of the centre pin.

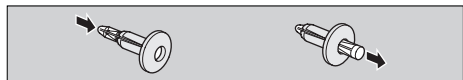

2. Insert the clip into the hole.
3. Press down on the centre pin to lock the clip.

Headlight Case

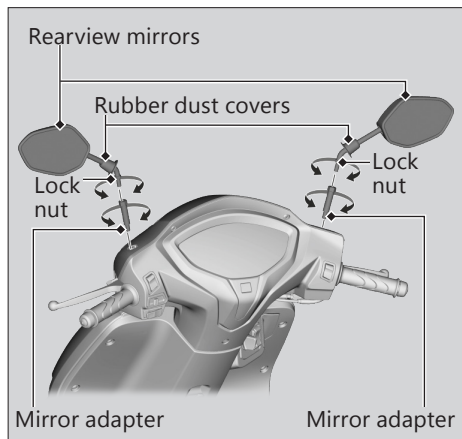

Removal

1. Pull up the rubber dust covers.
2. Loosen the lock nuts by turning clockwise.
3. Loosen the rearview mirrors and remove them by turning them clockwise until they will no longer turn.
4. Loosen the mirror adapters and remove them.

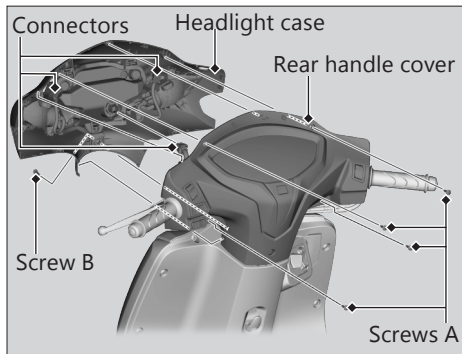

5. Remove the screws A and screw B.
6. Remove the headlight case, then disconnect the connectors.

Installation

Install the parts in the reverse order of removal.

► To install the rearview mirrors.

1. Install the mirror adapters.
2. Install the rearview mirrors by turning counterclockwise until they will no longer turn.
3. Loosen the rearview mirrors approximately 2 turns.
4. Adjust the rearview mirrors.
5. Tighten the lock nuts and install the rubber dust covers.

Checking Spark Plug

For the recommended spark plug, see "Specifications." ➤P. 123

Use only the recommended type of spark plug in the recommended heat range.

NOTICE

Using a spark plug with an improper heat range can cause engine damage.

1. Lift-up the body cover. ➤P. 67
2. Disconnect the spark plug cap from the spark plug.
3. Clean any dirt from around the spark plug base.
4. Remove the spark plug using provided spark plug wrench. ➤P. 64

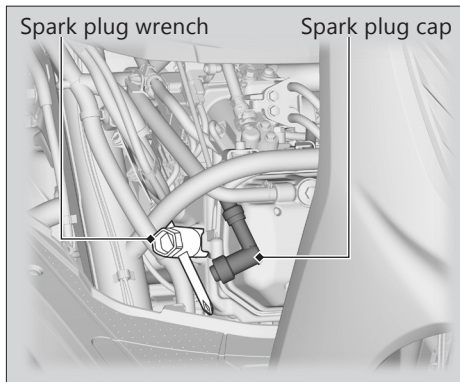

5. Inspect the electrodes and centre porcelain for deposits, erosion or carbon fouling.
 - ▶ If the erosion or deposit is heavy, replace the plug.
 - ▶ Clean a carbon or wet-fouled plug with a plug cleaner, otherwise use a wire brush.

Spark Plug ► Checking Spark Plug

6. Check the spark plug gap using a wire-type feeler gauge.
 - If adjustment is necessary, bend the side electrode carefully.

The gap should be:

0.8 to 0.9 mm (0.031 to 0.035 in)

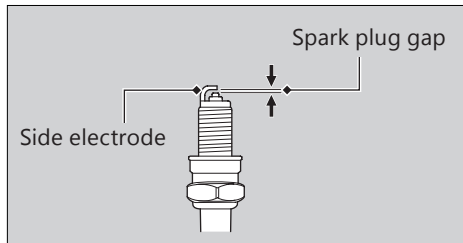

7. Make sure the plug washer is in good condition.
8. Install the spark plug. With the plug washer attached, thread the spark plug in by hand to prevent cross-threading.

9. Tighten the spark plug:
 - If the old plug is good:
 - 1/8 turn after it seats.
 - If installing a new plug, tighten it twice to prevent loosening:
 - a) First, tighten the plug:
 - 1/2 turn after it seats.
 - b) Then loosen the plug.
 - c) Next, tighten the plug again:
 - 1/8 turn after it seats.

NOTICE

An improperly tightened spark plug can damage the engine. If a plug is too loose, a piston may be damaged. If a plug is too tight, the threads may be damaged.

10. Install the parts in the reverse order of removal.
 - When reinstalling the spark plug cap, take care to avoid pinching any cables or wires.

Checking the Engine Oil

1. If the engine is cold, idle the engine for 3 to 5 minutes.
2. **SCV110S ID**
Turn the ignition switch to the OFF position and wait for 2 to 3 minutes.
SCV110S II ID
Turn the ignition switch to the **○** (Off) position and wait for 2 to 3 minutes.
3. Place your vehicle on its centre stand on a firm, level surface.
4. Remove the oil fill cap/dipstick and wipe it clean.
5. Insert the oil fill cap/dipstick until it seats, but don't screw it in.
6. Check that the oil level is between the upper level and lower level marks on the oil fill cap/dipstick.
7. Securely install the oil fill cap/dipstick.

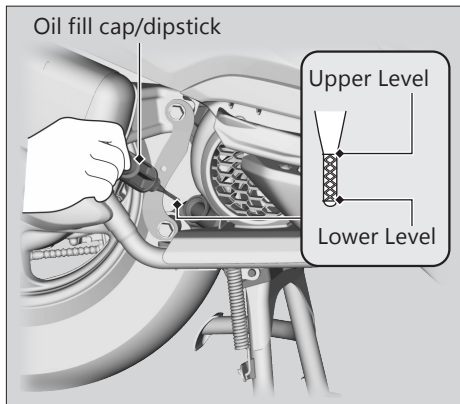

Adding Engine Oil

If the engine oil is below or near the lower level mark, add the recommended engine oil. ► P. 59, 123

1. Remove the oil fill cap/dipstick. Add the recommended oil until it reaches the upper level mark.
 - Place your vehicle on its centre stand on a firm, level surface when checking the oil level.
 - Do not overfill above the upper level mark.
 - Make sure no foreign objects enter the oil filler opening.
 - Wipe up any spills immediately.
2. Securely reinstall the oil fill cap/dipstick.

NOTICE

Overfilling with oil or operating with insufficient oil can cause damage to your engine. Do not mix different brands and grades of oil.

For the recommended oil and oil selection guidelines, see "Maintenance Fundamentals." ► P. 59

Changing Engine Oil, Cleaning Strainer Screen

Changing the oil and cleaning strainer screen requires special tools. We recommend that you have your vehicle serviced by your dealer.

1. If the engine is cold, idle the engine for 3 to 5 minutes.
2. **SCV110S ID**
Turn the ignition switch to the OFF position and wait for 2 to 3 minutes.
SCV110S II ID
Turn the ignition switch to the **○** (Off) position and wait for 2 to 3 minutes.

- Place your vehicle on its centre stand on a firm, level surface.
- Place a drain pan under the drain bolt and oil plug.
- Remove the oil fill cap/dipstick, drain bolt, and sealing washer to drain the oil.
- Remove the oil plug, O-ring, spring and oil strainer screen and let the remaining oil drain out.
 - Discard the oil at an approved recycling centre.
- Clean the oil strainer screen.
- Check that the oil strainer screen and sealing rubber are in good condition.
- Replace the O-ring and apply a thin coat of engine oil to the new O-ring before installing it.
- Install the oil strainer screen, spring and oil plug and tighten.

Torque: 20 N·m (2.0 kgf·m, 15 lbf·ft).

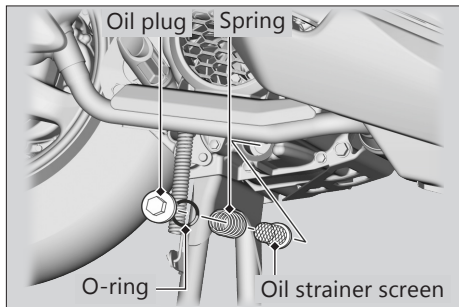
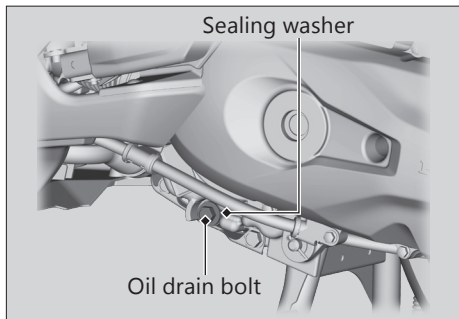

Engine Oil ► Changing Engine Oil, Cleaning Strainer Screen

11. Install a new sealing washer onto the drain bolt. Tighten the drain bolt.

Torque: 24 N·m (2.4 kgf·m, 18 lbf·ft).

12. Fill the crankcase with the recommended oil (►P. 46, 96) and install the oil fill cap/dipstick.

Required oil

When changing oil & cleaning the strainer screen:

0.60 litres (0.65 US qt, 0.53 Imp qt)

When changing oil only:

0.55 litres (0.60 US qt, 0.48 Imp qt)

13. Check the oil level. ►P. 73
14. Check that there are no oil leaks.

Inspecting the Brake Lever Freeplay

1. Place your vehicle on its centre stand on a firm, level surface.
2. Measure the distance the front and rear brake levers move before each brake takes hold.

Freeplay at the tip of the brake lever: 10 to 20 mm (0.4 to 0.8 in)

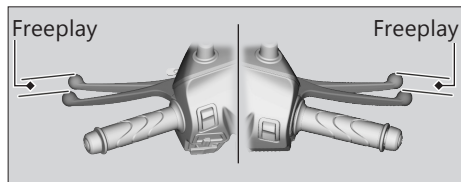

Adjusting the Brake Lever Freeplay

Adjust the freeplay of the brake levers with the front wheel pointed straight ahead in the order of front brake followed by rear brake. Make sure the cut-out on the adjusting nut is seated on the brake arm pin when adjusting the freeplay.

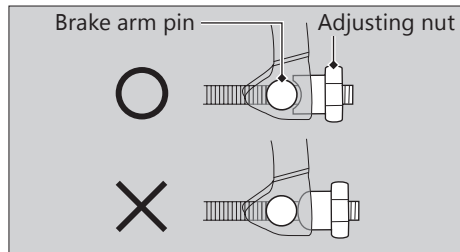

If proper adjustment cannot be obtained by this method, see your dealer.

Brakes ▶ Adjusting the Brake Lever Freeplay

1. Turn No.1 adjusting nut a half-turn at a time while firmly pushing the brake arm. Check the freeplay of the front brake lever after turning the adjusting nut clockwise (less freeplay) by hand until the nut no longer turns.

▶ If the freeplay of the front brake lever is out of the specified range, readjust the freeplay by rotating the No.1 adjusting nut.

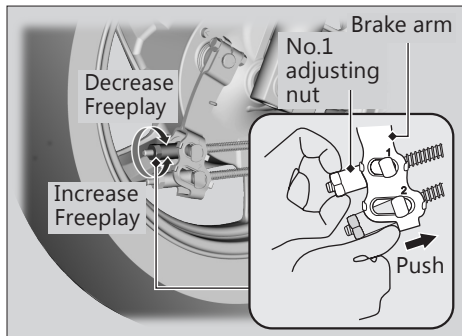

2. Without pushing the brake arm, adjust No.2 adjusting nut so that the gaps between the brake arm and brake arm pin for No.1 and No.2 are as follows.

Gap of No.1 : no gap

Gap of No.2 : approximately 1 mm (0.04 in)

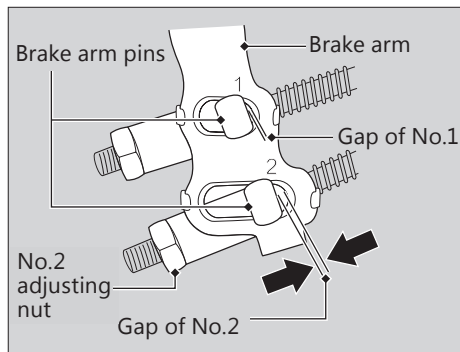

To adjust No.2 adjusting nut, turn the No.2 adjusting nut a half-turn at a time while firmly pushing the brake arm.

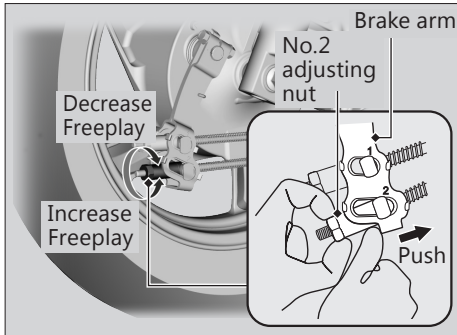

3. While pushing the front brake arm, confirm there is a gap between the brake arm and brake arm pin for No.1 and No.2.

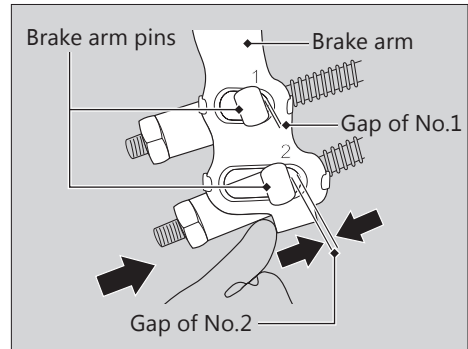

Brakes ► Adjusting the Brake Lever Freeplay

4. Apply the brakes several times and check for free wheel rotation after the front and rear brake levers are released.

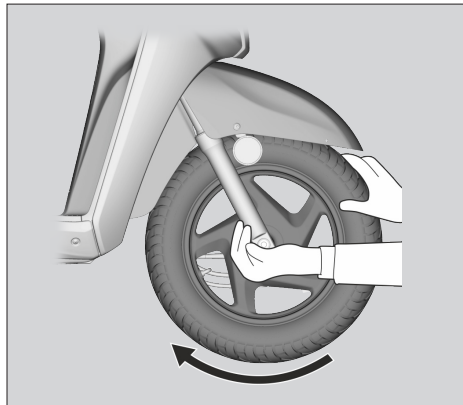

5. Adjust the freeplay of the rear brake lever by turning the rear brake adjusting nut a half-turn at a time.

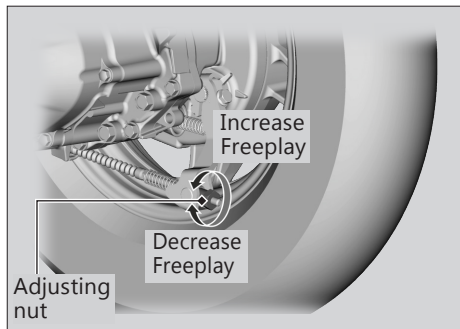

6. Push the brake arm to confirm that there is a gap between the rear brake adjusting nut and brake arm pin.

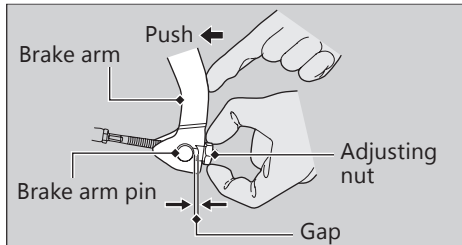

7. Apply the brake several times and check for free wheel rotation after the brake lever is released.

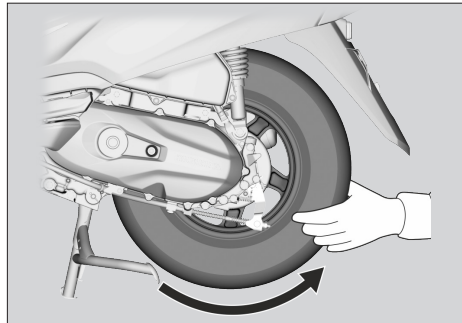

After adjustment, confirm the freeplay of the brake levers.

NOTICE

Do not turn the adjuster beyond its natural limits.

Make sure the brake arm, spring and fastener are in good condition.

Inspecting the Brake Shoe Wear

The front and rear brake are equipped with a brake wear indicator.

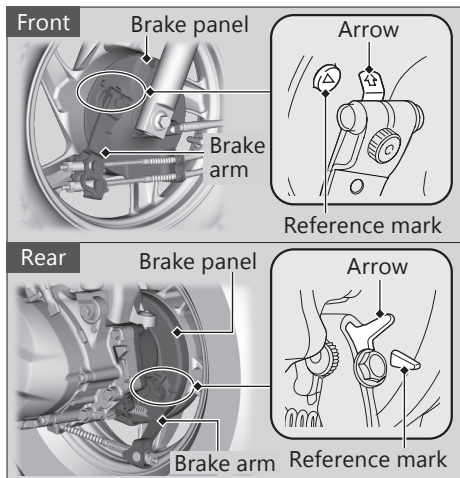

When the brake is applied, an arrow attached to the brake arm moves toward a reference mark on the brake panel. If the arrow aligns with the reference mark on full application of the brake, the brake shoes must be replaced. See your dealer for this service.

When brake service is necessary, see your dealer. Use only Honda Genuine Parts or their equivalent.

Checking the Throttle

With the engine off, check that the throttle rotates smoothly from fully closed to fully open in all steering positions and throttle freeplay is correct. If the throttle does not move smoothly or close automatically, or if the cable is damaged, have the vehicle inspected by your dealer.

Freeplay at the throttle grip flange:

2 to 6 mm (0.1 to 0.2 in).

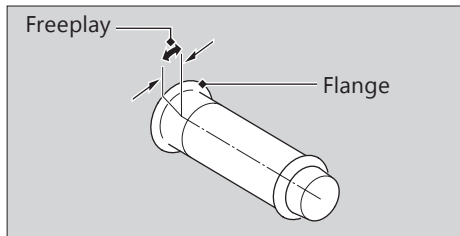

Cleaning the Crankcase Breather

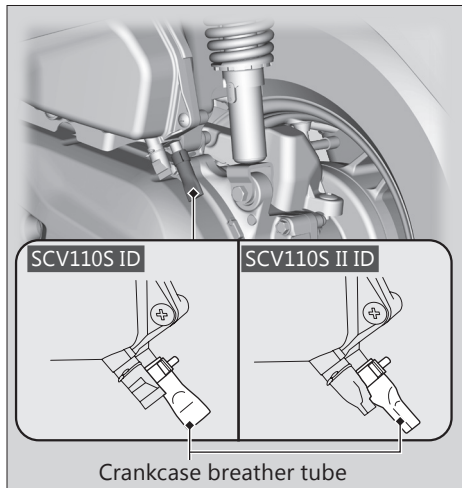

1. Place a suitable container to receive deposits.
2. Remove the crankcase breather tube and drain deposits.
3. Reinstall the crankcase breather tube.

Adjusting the Headlight Aim

You can adjust vertical aim of the headlight for proper alignment. To move the headlight, loosen the bolt.

Tighten the bolt after adjustment.

Obey local laws and regulations.

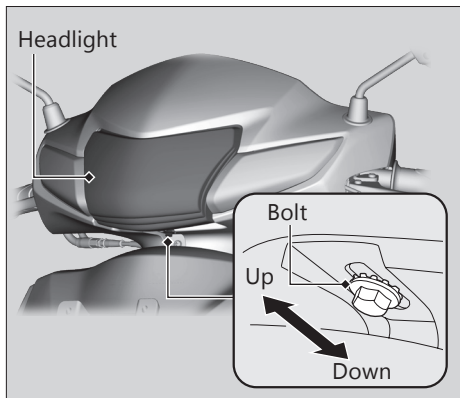

Adjusting the Rear Suspension

Adjusting the suspension requires a pin spanner, we recommend that you have your vehicle serviced by your dealer.

Spring Preload

You can adjust the spring preload by the adjuster to suit the load or the road surface. Use the pin spanner to turn the adjuster. Position 1 is for a decrease spring preload (soft), or turn the position 3 increase spring preload (hard). The standard position is 2.

NOTICE

Attempting to adjust directly from 1 to 3 or 3 to 1 may damage the shock absorber.

NOTICE

Do not turn the adjuster beyond its limits.

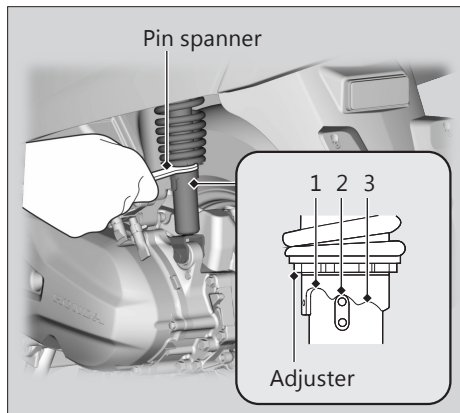

Replacing the Honda SMART Key Battery

SCV110S II ID

If the Honda SMART Key indicator flashes 5 times when the ignition switch is turned to the (On) position, or the operating range becomes unstable, replace the battery as soon as possible.

We recommend to see your dealer for this service.

Battery type: CR2032

1. Remove the upper case by inserting a coin or a flat head screwdriver covered with a protective cloth into the slit.
 - ▶ Wrap a coin or a screwdriver with a protective cloth to prevent scratching the Honda SMART Key.
 - ▶ Do not touch the circuit or terminal. This may cause problems.
 - ▶ Be careful to avoid scratching the waterproof covering or allowing dust to enter.
 - ▶ Do not forcibly dismantle the Honda SMART Key body.

Other Replacement ► Replacing the Honda SMART Key Battery

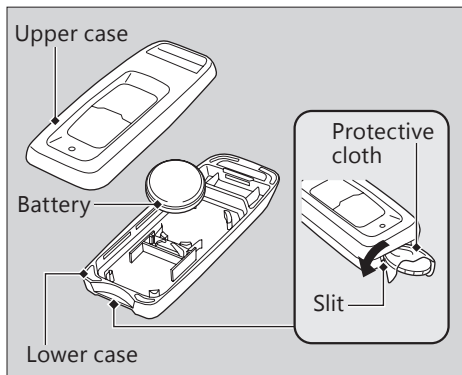

2. Replace the old battery with a new battery with the negative \ominus side facing up.
3. Snap the two halves of the remote transmitter back together.
 - Make sure that upper and lower cases are set in the right position.

⚠️ WARNING

CHEMICAL BURN HAZARD

The battery that powers the Honda SMART Key can cause severe internal burns and can even lead to death if swallowed.

Keep new and used batteries away from children.

If you suspect that a child has swallowed the battery, seek medical attention immediately.

CAUTION:

- Danger of explosion if battery is incorrectly replaced. Replace only with the same or equivalent type.
- Do not exposed to excessive heat such as sunshine, fire or the like, that can result in an explosion or the leakage of flammable liquid or gas during use, storage or transportation.
- Do not dispose of a battery into fire or a hot oven, or give mechanically crushing or cutting of a battery, that can result in an explosion.
- Do not subjected to extremely low air pressure at high altitude that may result in an explosion or the leakage of flammable liquid or gas.

Troubleshooting

Engine Will Not Start	P. 91	Tyre Puncture	P. 102
Warning Indicators On or Flashing	P. 92	Electrical Trouble	P. 103
PGM-FI (Programmed Fuel Injection)		Battery Goes Dead.....	P. 103
Malfunction Indicator Lamp (MIL).....	P. 92	Burned-out Light Bulb.....	P. 103
Battery Charging Condition indicator.....	P. 93	Blown Fuse.....	P. 106
Honda SMART Key Indicator	P. 93	Unstable Engine Operation Occurs	
When the Honda SMART Key System		Intermittently	P. 107
Does Not Operate Properly	P. 95		
Unlock the Seat in an Emergency	P. 97		
Unlock the Ignition Switch in an			
Emergency	P. 99		

Starter Motor Operates But Engine Does Not Start

Check the following items:

- Check the correct engine starting sequence. ➤P. 37
- Check that there is petrol in the fuel tank.
- Check if the PGM-FI malfunction indicator lamp (MIL) is on.
 - ▶ If the indicator lamp is on, contact your dealer as soon as possible.

Starter Motor Does Not Operate

Check the following items:

- Check the correct engine starting sequence. ➤P. 37
- Check for a blown fuse. ➤P. 106
- Check for a loose battery connection (➤P. 65) or battery terminal corrosion (➤P. 58).
- Check the condition of the battery. ➤P. 103

If the problem continues, have your vehicle inspected by your dealer.

PGM-FI (Programmed Fuel Injection) Malfunction Indicator Lamp (MIL)

Reasons for the indicator lamp to come on or blink

- Comes on if there is a problem with the engine emissions control system.
- Blinks when engine misfiring is detected.

What to do when the indicator lamp comes on

Avoid high speeds and immediately get your vehicle inspected at a dealer.

NOTICE

If you drive with the malfunction indicator lamp on, the emissions control system and the engine could be damaged.

What to do when the indicator lamp blinks

Park the vehicle in a safe place with no flammable items and wait at least 10 minutes with the engine stopped until it cools.

NOTICE

If the malfunction indicator lamp blinks again when restarting the engine, drive to the nearest dealer at 50 km/h (30 mph) or less. Have your vehicle inspected.

Battery Charging Condition indicator

SCV110S II ID

If the indicator comes on while riding, you may have a condition of low battery voltage or battery performance degradation. Have your vehicle inspected by your dealer.

The indicator may not come on:

- If the battery does not have enough voltage to drive the indicator system.
- If the vehicle was started with external power source.
- If the vehicle has an unspecified battery.

Honda SMART Key Indicator

SCV110S II ID

When the Honda SMART Key indicator flashes 5 times

Replacing the Honda SMART Key Battery ► P. 87

When the Honda SMART Key indicator is flashing while the ignition switch is in the (On) position

The Honda SMART Key indicator flashes when communication between your vehicle and Honda SMART Key stops after turning the ignition switch to the (On) position.

It is probably caused by the following:

- Strong radio waves or noise are affecting the system

Warning Indicators On or Flashing ► Honda SMART Key Indicator

- You lose the Honda SMART Key while riding

However, this does not affect the operation of your vehicle until the ignition switch is locked.

If you turn the ignition switch to the SEAT FUEL, ○ (Off) or  (Lock) position while the Honda SMART Key indicator is flashing, the Honda SMART Key indicator will flash faster for about 20 seconds, automatically goes off, and then the ignition switch will lock.

- Turn signal lights blink at the beginning and end of this function.

To stop this flashing, press and hold the ignition switch for more than 2 seconds. After the flashing stops, the ignition switch is locked.

If you do not have the Honda SMART Key, the ignition switch can be unlocked in another way.  P. 99

When the Honda SMART Key System Does Not Operate Properly

SCV110S II ID

When the Honda SMART Key system does not work properly, perform the following.

- Check that the Honda SMART Key system is activated.

Lightly press the ON/OFF button on the Honda SMART Key.

If the Honda SMART Key LED is red, activate the Honda SMART Key system.

➔ P. 26

If the Honda SMART Key LED does not respond, replace the battery. ➔ P. 87

- Check that there is no communication failure in the Honda SMART Key system. The Honda SMART Key system uses lowintensity radio waves. The Honda SMART Key system may not work properly in the following conditions:
 - ▶ When there are facilities nearby that generate strong radio waves or noise such as TV towers, power stations, radio stations, or airports.
 - ▶ When you carry the Honda SMART Key with a laptop or wireless communication device such as a radio or mobile phone.
 - ▶ When the Honda SMART Key comes into contact with or is covered by metal objects.

When the Honda SMART Key System Does Not Operate Properly

- Check that a registered Honda SMART Key is used.
Use a registered Honda SMART Key.
The Honda SMART Key system cannot be activated without a registered Honda SMART Key.
- Make sure that you do not use a broken Honda SMART Key.
If you use a broken Honda SMART Key, the Honda SMART Key system cannot be activated. Bring the emergency key and ID tag to your dealer.

- Check the battery condition and battery lead in your vehicle.
Check the battery and battery terminals. If the battery is weak, contact your dealer.

If the Honda SMART Key system cannot be activated due to other causes, contact your dealer.

Unlock the Seat in an Emergency

SCV110S II ID

The seat lock can be unlocked by using the emergency key.

Open

1. Pull out the front lid.

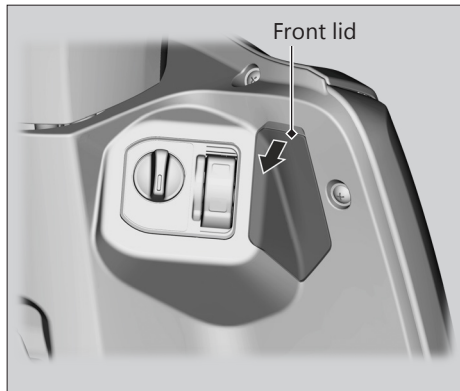

2. Align the projection of the emergency key with the slot of the emergency seat opener, and turn the emergency key counterclockwise.
3. Open the seat and turn the emergency key clockwise.

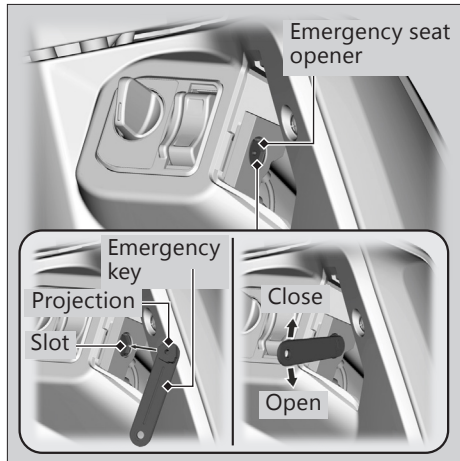

Unlock the Seat in an Emergency

Close

1. Close and push down on the rear of the seat until it locks. Make sure that the seat is locked securely by pulling it up lightly. If the seat is not locked, turn the emergency key clockwise to lock the seat catch.
2. Install the front lid. Make sure that all tabs are installed securely in position.

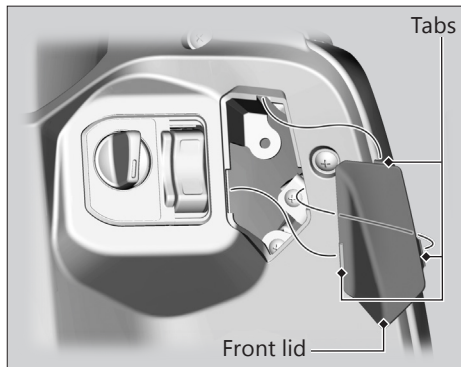

Unlock the Ignition Switch in an Emergency



SCV110S II ID

Set up to ID number input mode

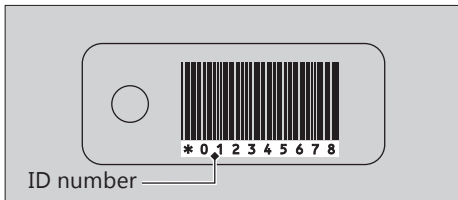
1. Check the ID number on the ID tag.
2. Push and hold the ignition switch for more than 4 seconds. The Honda SMART Key indicator starts blinking.
3. Push the ignition switch while the Honda SMART Key indicator is blinking, then the Honda SMART Key indicator changes from blinking to lighting.
 - ▶ This means that you can input the ID number.



ID number input

You can input your ID number by pressing the ignition switch when the ignition switch is in the  (Off),  (Lock) or SEAT FUEL position.

Input the ID number on the ID tag in order from the left in turn by pressing the ignition switch.

The ID number is authenticated according to the number of times the ignition switch is pushed.

Push the ignition switch the desired number of times within 5 seconds when the Honda SMART Key indicator comes on. After 5 seconds, the Honda SMART Key indicator goes off and comes on again. This means that the inputted number is fixed, and you can input the next number.

Unlock the Ignition Switch in an Emergency

Example:

- To input "0", wait for 5 seconds without pushing the ignition switch when the Honda SMART Key indicator comes on.
- To input "1", push the ignition switch once within 5 seconds when the Honda SMART Key indicator comes on.

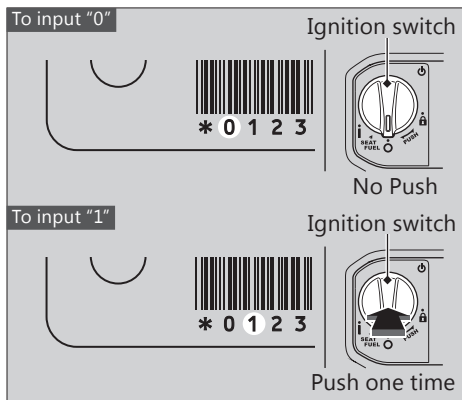

ID number input success

After the last ID number is inputted, the Honda SMART Key indicator will go off and come on again.

The ignition switch is then unlocked. Turn the ignition switch to the **I** (On) position within 6 minutes. You can start the engine.

To lock the ignition switch, turn the ignition switch to the SEAT FUEL, **O** (Off), or **L** (Lock) position, and push and hold the ignition switch for about 2 seconds. All turn signals flash once.

Unlock the Ignition Switch in an Emergency

The ignition switch also locks automatically when the ignition switch has been in the SEAT FUEL, ○ (Off), or  (Lock) position for about 6 minutes after the ID number is successfully inputted.

When the ignition switch is locked, the Honda SMART Key indicator goes off. To unlock the ignition switch again, repeat the procedure for unlocking the ignition switch.

ID number input failure

After the last ID number is inputted, the Honda SMART Key Indicator will flash every second, and the ignition switch cannot be unlocked.

Follow the procedure again. ➡ P. 99

ID number input cancel

Push and hold the ignition switch for about 2 seconds.

Also, if you make a mistake while inputting the ID number, re-input the ID number from the beginning. ➡ P. 99

Tyre Puncture

Repairing a puncture or removing a wheel requires special tools and technical expertise. We recommend you have this type of service performed by your dealer.

After an emergency repair, always have the tyre inspected/replaced by your dealer.

Emergency Repair Using a Tyre Repair Kit

If your tyre has a minor puncture, you can make an emergency repair using a tubeless tyre repair kit.

Follow the instructions provided with the emergency tyre repair kit.

Riding your vehicle with a temporary tyre repair is very risky. Do not exceed 50 km/h (30 mph). Have the tyre replaced by your dealer as soon as possible.

WARNING

Riding your vehicle with a temporary tyre repair can be risky. If the temporary repair fails, you can crash and be seriously injured or killed.

If you must ride with a temporary tyre repair, ride slowly and carefully and do not exceed 50 km/h (30 mph) until the tyre is replaced.

Battery Goes Dead

Charge the battery using a motorcycle battery charger.

Remove the battery from the vehicle before charging.

Do not use an automobile-type battery charger, as these can overheat a motorcycle battery and cause permanent damage.

If the battery does not recover after recharging, contact your dealer.

NOTICE

Jump starting using an automobile battery can damage your vehicle's electrical system and is not recommended.

Burned-out Light Bulb

Follow the procedure below to replace a burned-out light bulb.

SCV110S ID

Turn the ignition switch to the OFF or LOCK position.

SCV110S II ID

Turn the ignition switch to the ○ (Off) or  (Lock) position.

Allow the bulb to cool before replacing it. Do not use bulbs other than those specified. Check the replacement bulb for correct operation before riding.

For the light bulb wattage, see "Specifications." ➔ P. 124

| Headlight

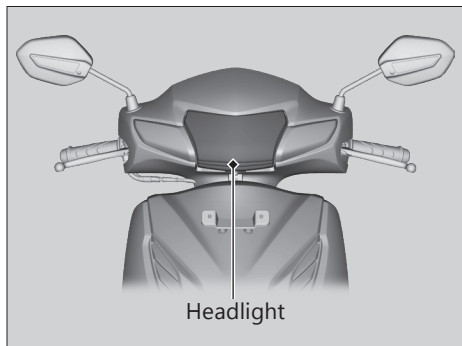

The headlight uses several LEDs. If there is an LED which is not turned on, see your dealer for servicing.

| Brakelight/Taillight Bulb

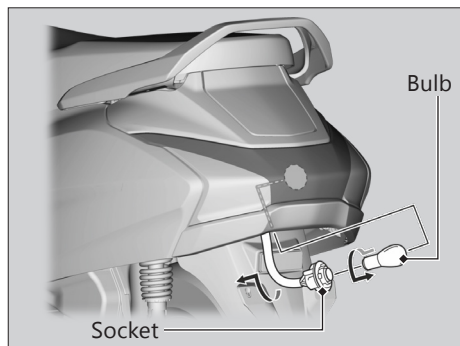

- 1.** Insert the hand from rear side to reach behind the brakelight/taillight assembly.
- 2.** Turn the socket counterclockwise and pull it out.
- 3.** Slightly press the bulb and turn it counterclockwise.
- 4.** Install a new bulb and parts in the reverse order of removal.

Front Turn Signal Bulb

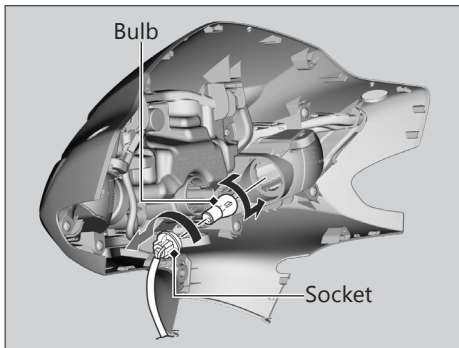

1. Remove the headlight case. ► P. 69
2. Turn the socket counterclockwise and pull it out.
3. Slightly press the bulb and turn it counterclockwise.
4. Install a new bulb and parts in the reverse order of removal.
 - Use only the amber bulb

Rear Turn Signal Bulb

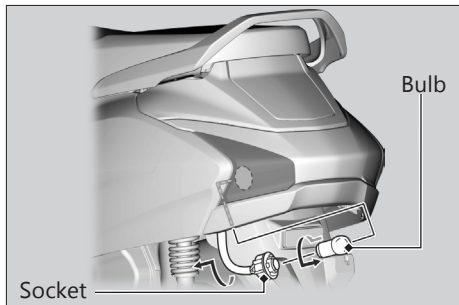

1. Insert the hand from rear side to reach behind the brakelight/taillight assembly.
2. Turn the socket counterclockwise and pull it out.
3. Slightly press the bulb and turn it counterclockwise.
4. Install a new bulb and parts in the reverse order of removal.
 - Use only the amber bulb

Blown Fuse

Before handling fuses, see “Inspecting and Replacing Fuses.” ► P. 59

| Main Fuse & FI Fuse

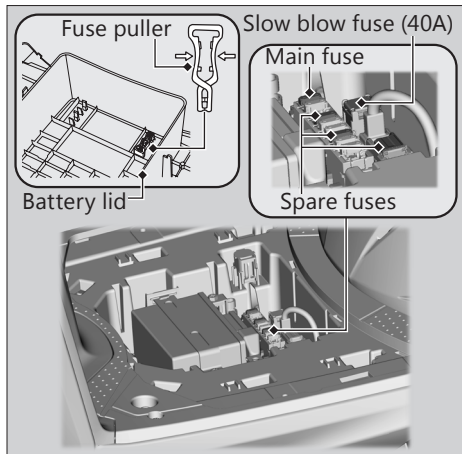

1. Remove the battery lid. ► P. 66
2. Pull the fuses out one by one with the fuse puller and check for a blown fuse. Always replace a blown fuse with a spare fuse of the same rating.
► Fuse puller is provided in the battery lid.
3. Reinstall parts in the reverse order of removal.

NOTICE

If a fuse fails repeatedly, you likely have an electrical problem. Have your vehicle inspected by your dealer.

Unstable Engine Operation Occurs Intermittently

If the fuel pump filter is clogged, unstable engine operation will occur intermittently while riding.

Even if this symptom occurs, you can continue to ride your vehicle.

If unstable engine operation occurs even if sufficient fuel is available, have your vehicle inspected by your dealer as soon as possible.

Information

Service Diagnostic Recorders	P. 109
Keys	P. 109
Ignition Key.....	P. 109
Emergency Key.....	P. 110
Honda SMART Key.....	P. 110

Instruments, Controls, &

Other Features	P. 113
Caring for Your Vehicle	P. 114
Storing Your Vehicle	P. 117
Transporting Your Vehicle	P. 117
You & the Environment	P. 118
Serial Numbers	P. 119

Fuels Containing Alcohol	P. 120
Catalytic Converters	P. 121

Service Diagnostic Recorders

Your vehicle is equipped with service-related devices that record information about powertrain performance and riding conditions. The data can be used to help technicians diagnose, repair and maintain the vehicle. This data may not be accessed by anyone else except as legally required or with the permission of the vehicle owner. However this data may be accessed by Honda, its authorised dealers and authorised repairers, employees, representatives and contractors only for the purpose of the technical diagnosis, research and development of the vehicle.

Keys

Ignition key

SCV110S ID

Be sure to record the key number provided with the key number plate. Store the spare key and key number in a safe location.

To make a duplicate, take the spare key or the key number to your dealer.

If you lose all ignition keys and the key number, the ignition switch and key shutter set will need to be replaced.

A metal key holder may cause damage to the area surrounding the ignition switch.

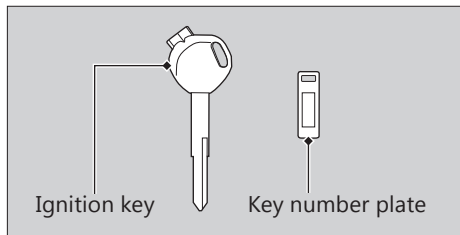

Emergency Key

SCV110S II ID

The emergency key is used for an emergency.

- To unlock the seat. ➤ P. 97

Do not store the emergency key in any compartment.

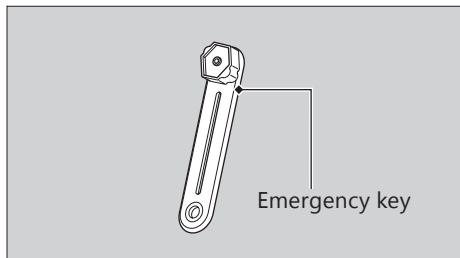

Honda SMART Key

SCV110S II ID

Carrying the Honda SMART Key allows you to perform the following operations:

- Locking or unlocking the ignition switch
- Releasing the seat or fuel fill cap lock
- Locking or unlocking the steering

The ID number of the Honda SMART Key is on the ID tag. You can also unlock the ignition switch by inputting the ID number.

Always carry both the emergency key and ID tag, but separate from the Honda SMART Key, to avoid losing all of them at the same time.

Also store a copy of your ID number in a safe place other than your vehicle.

The Honda SMART Key contains electronic circuits. If the circuits are damaged, the Honda SMART Key will not allow you to perform any operations.

- Do not drop the Honda SMART Key or set heavy objects on them.
- Protect the Honda SMART Key from direct sunlight, high temperature, and high humidity.
- Do not scratch or puncture.
- Do not store near any magnetized products such as a magnetized key chain.
- Always keep the Honda SMART Key away from electric appliances such as a TV, radio, PC or low-frequency massage device.
- Keep the Honda SMART Key away from liquids. If it gets wet, dry it immediately with a soft cloth.

- Keep the Honda SMART Key away from the vehicle while washing the vehicle.
- Do not burn.
- Do not wash in an ultrasonic cleaner.
- If fuel, wax, or grease adhere to the Honda SMART Key, wipe it off immediately to avoid cracking or warping.
- Do not disassemble the Honda SMART Key other than when changing a battery. Only the cover of the Honda SMART Key can be disassembled. Do not disassemble other parts.
- Do not lose your Honda SMART Key. If you lose it, you will need to register a new Honda SMART Key. See your dealer with your emergency key and ID tag for registration.

Keys

The battery in the Honda SMART Key system normally lasts about 2 years.

Do not keep mobile phones or other radio transmitting devices in any compartment. The radio frequency from the devices will interrupt the Honda SMART Key system.

To get an additional Honda SMART Key, take the Honda SMART Key and the vehicle to your dealer.

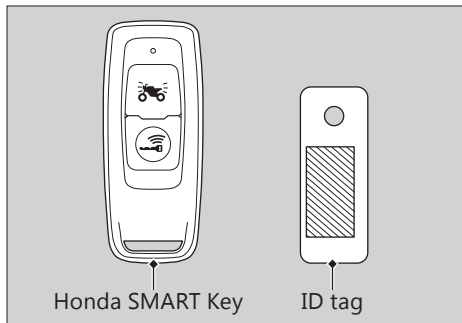

Instruments, Controls, & Other Features

Ignition Switch

SCV110S ID

Leaving the ignition switch in the ON position with the engine stopped will drain the battery. Do not turn the key while riding.

SCV110S II ID

Leaving the ignition switch in the **I** (On) position with the engine stopped will drain the battery. Do not turn the ignition switch while riding.

Engine Stop Switch

Do not use the engine stop switch except in an emergency. Doing so when riding will cause the engine to suddenly turn off, making riding unsafe.

SCV110S ID

If you stop the engine using the engine stop switch, turn the ignition switch to the OFF position. Failing to do so will drain the battery.

SCV110S II ID

If you stop the engine using the engine stop switch, turn the ignition switch to the **O** (Off) position. Failing to do so will drain the battery.

Odometer

The odometer resets to 0 when the odometer mileage exceeds 99,999.9.

Document Bag

The owner's manual, registration, and insurance information can be stored in the plastic document bag located in the document compartment in the centre compartment.

➤ P. 48

Caring for Your Vehicle

Frequent cleaning and polishing is important to ensure the life of your Honda. A clean vehicle makes it easier to spot potential problems. In particular, seawater and salts used to prevent ice on roads promote the formation of corrosion. Always wash your vehicle thoroughly after riding on coastal or treated roads.

Washing

Allow the engine, muffler, brakes, and other high-temperature parts to cool before washing.

1. Rinse your vehicle thoroughly using a low pressure garden hose to remove loose dirt.
2. If necessary, use a sponge or a soft towel with mild cleaner to remove road grime.
 - ▶ Clean the headlight lens, panels, and other plastic components with extra care to avoid scratching them. Avoid directing water into the air cleaner, muffler, and electrical parts.

3. Thoroughly rinse your vehicle with plenty of clean water and dry with a soft, clean cloth.
4. After the vehicle dries, lubricate any moving parts.
 - ▶ Make sure that no lubricant spills onto the brakes or tyres. Brake discs, pads, drum or shoes contaminated with oil will suffer greatly reduced braking effectiveness and can lead to a crash.
5. Apply a coat of wax to prevent corrosion.
 - ▶ Avoid products that contain harsh detergents or chemical solvents. These can damage the metal, paint, and plastic on your vehicle.
Keep the wax clear of the tyres and brakes.
 - ▶ If your vehicle has any matte painted parts, do not apply a coat of wax to the matte painted surface.

Washing Precautions

Follow these guidelines when washing:

- Do not use high-pressure washers:
 - ▶ High-pressure water cleaners can damage moving parts and electrical parts, rendering them inoperable.
 - ▶ Water in the air intake can be drawn into the throttle body and/or enter the air cleaner.
 - Do not direct water at the muffler:
 - ▶ Water in the muffler can prevent starting and causes rust in the muffler.
 - Dry the brakes:
 - ▶ Water adversely affects braking effectiveness. After washing, apply the brakes intermittently at low speed to help dry them.
 - Do not direct water under the seat:
 - ▶ Water in the under seat compartment can damage your documents and other belongings.
-
- Do not direct water at the air cleaner:
 - ▶ Water in the air cleaner can prevent the engine from starting.
 - Do not direct water near the headlight:
 - ▶ The headlight's inside lens may fog temporarily after washing or while riding in rain. This does not impact the headlight function. However, if you see a large amount of water or ice accumulated inside the lens(es), have your vehicle inspected by your dealer.
 - Do not use wax or polishing compounds on matte painted surfaces:
 - ▶ Use a soft cloth or sponge, plenty of water, and a mild detergent to clean matte painted surfaces. Dry with a soft clean cloth.

Aluminium Components

Aluminium will corrode from contact with dirt, mud, or road salt. Clean aluminium parts regularly and follow these guidelines to avoid scratches:

- Do not use stiff brushes, steel wool, or cleaners containing abrasives.
- Avoid riding over or scraping against curbs.

Panels

Follow these guidelines to prevent scratches and blemishes:

- Wash gently using a soft sponge and plenty of water.
- To remove stubborn stains, use diluted detergent and rinse thoroughly with plenty of water.
- Avoid getting petrol or detergents on the instruments, panels, or headlight.

Exhaust Pipe and Muffler

If the exhaust pipe and muffler are painted, do not use a commercially available abrasive kitchen cleaning compound. Use a neutral detergent to clean the painted surface on the exhaust pipe and muffler. If you are not sure if your exhaust pipe and muffler are painted, contact your dealer.

Storing Your Vehicle

If you store your vehicle outdoors, you should consider using a full-body cover.

If you won't be riding for an extended period, follow these guidelines:

- Wash your vehicle and wax all painted surfaces (except matte painted surfaces). Coat chrome pieces with rust-inhibiting oil.
- Place your vehicle on its centre stand and position a block so that both tyres are off the ground.
- After rain, remove the body cover and allow the vehicle to dry.
- Remove the battery (➔ P. 65) to prevent discharge. Fully charge the battery and then place it in a shaded, well-ventilated area.
 - ▶ If you leave the battery in place, disconnect the negative \ominus terminal to prevent discharge.

After removing your vehicle from storage, inspect all maintenance items required by the Maintenance Schedule.

Transporting Your Vehicle

If your vehicle needs to be transported, it should be carried on a motorcycle trailer or a flatbed truck or trailer that has a loading ramp or lifting platform and motorcycle tie-down straps. Never try to tow your vehicle with a wheel or wheels on the ground.

NOTICE

Towing your vehicle with a wheel or wheels on the ground can cause serious damage to the transmission.

You & the Environment

Owning and riding a vehicle can be enjoyable, but you must do your part to protect the environment.

Choose Sensible Cleaners

Use a biodegradable detergent when you wash your vehicle. Avoid aerosol spray cleaners that contain chlorofluorocarbons (CFCs) which damage the atmosphere's protective ozone layer.

Recycle Wastes

Put oil and other toxic wastes in approved containers and take them to a recycling centre. Call your local or state office of public works or environmental services to find a recycling centre in your area and to get instructions on how to dispose of non-recyclable wastes. Do not place used engine oil in the trash or pour it

down a drain or on the ground. Used oil, petrol, and cleaning solvents contain poisons that can hurt refuse workers and contaminate drinking water, lakes, rivers, and oceans.

Serial Numbers

The frame and engine serial numbers uniquely identify your vehicle and are required in order to register your vehicle. They may also be required when ordering replacement parts. You should record these numbers and keep them in a safe place.

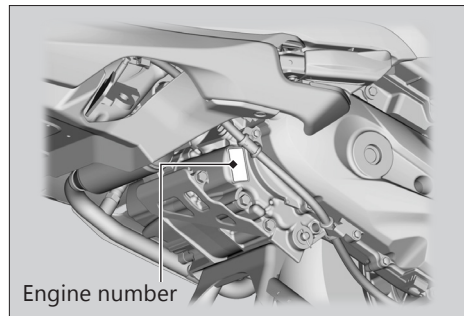
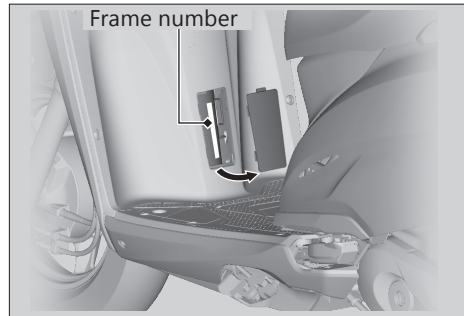

Fuels Containing Alcohol

Some conventional fuels blended with alcohol are available in some locales to help reduce emissions to meet clean air standards. If you plan to use blended fuel, check that it is unleaded and meets the minimum octane rating requirement.

The following fuel blends can be used in your vehicle:

- Ethanol (ethyl alcohol) up to 10% by volume.
 - ▶ Petrol containing ethanol may be marketed under the name Gasohol.

The use of petrol containing more than 10% ethanol may:

- Cause poor drivability and affect mileage.



This mark means that the vehicle parts are compliant up to 20% Ethanol blending with petrol.

NOTICE

Use of blended fuels containing higher than approved percentages can damage metal, rubber, plastic parts of your fuel system.

If you notice any undesirable operating symptoms or performance problems, try a different brand of petrol.

Catalytic Converters

This vehicle is equipped with a three-way catalytic converter. The catalytic converter contains precious metals that serve as catalysts in high temperature chemical reactions that convert hydrocarbons (HC), carbon monoxide (CO), and oxides of nitrogen (NOx) in the exhaust gases into safe compounds.

A defective catalytic converter contributes to air pollution and can impair your engine's performance. A replacement unit must be an original Honda part or equivalent.

Follow these guidelines to protect your vehicle's catalytic converter:

- Always use unleaded petrol. Leaded petrol will damage the catalytic converter.
- Keep the engine in good running condition.
- Have your vehicle serviced if your engine is misfiring, backfiring, stalling, or otherwise not running properly, stop riding and turn off the engine.

Specifications

■ Main Components

Overall length	1833 mm (72.2 in)
Overall width	697 mm (27.4 in)
Overall height	1156 mm (45.5 in)
Wheelbase	1260 mm (49.6 in)
Minimum ground clearance	162 mm (6.4 in)
Caster angle	27° 30'
Trail	72 mm (2.8 in)
Curb weight	105 kg (231 lbs)
Maximum weight capacity* ¹	174 kg (384 lbs)
Maximum luggage weight* ²	Centre compartment 10 kg (22 lbs)
	Luggage hook 1.5 kg (3 lbs)
Passenger capacity	Rider and 1 passenger
Minimum turning radius	1.96 m (6.43 ft)

*1 Including rider, passenger, all luggage, and accessories

*2 Includes the weight of the luggage and added accessories.

Displacement	109.51 cm ³ (6.68 cu-in)
Bore x stroke	47.000 x 63.121 mm (1.850 × 2.485 in)
Compression ratio	10.0:1
Fuel	Unleaded petrol Recommended: 91 RON or higher
Fuel containing alcohol	ETHANOL up to 10% by volume as per certification
Tank capacity	5.3 litres (1.4 US gal, 1.17 Imp gal)
Battery	ID ETZ4/ ATZ4L/ YTZ4 12 V - 3 Ah (10 HR)
	II ID ATZ4L 12 V - 3 Ah (10 HR)
Primary reduction	V-Matic (2.55:1 to 0.80:1)
Final reduction	10.208

■ Service Data

Tyre size	Front	90/90-12 54J
	Rear	90/100-10 53J
Tyre type	Tubeless	
Recommended tyres	Front	NYLOGRIP ZAPPER-FG (MRF) ZOOM-Hi (CEAT)
	Rear	NYLOGRIP ZAPPER (MRF) ZOOM-D (CEAT)
Tyre air pressure	Front	(Driver only) 150 kPa (1.50 kgf/cm ² , 22 psi) (Driver and passenger) 150 kPa (1.50 kgf/cm ² , 22 psi)
	Rear	(Driver only) 200 kPa (2.00 kgf/cm ² , 29 psi) (Driver and passenger) 250 kPa (2.50 kgf/cm ² , 36 psi)
Spark plug	MR8E-9 (NGK) / UR5DE0 (BOSCH)	
Spark plug gap	0.8 to 0.9 mm (0.031 to 0.035 in)	

Idle speed	1600 ± 100 rpm	
Recommended engine oil	Honda 4-stroke motorcycle oil API Service Classification SJ or higher, excluding oils marked as "Energy Conserving" or "Resource Conserving," SAE 5W-30, JASO T 903 standard MB	
Engine oil capacity	After draining	0.55 litres (0.60 US qt, 0.48 Imp qt)
	After draining & cleaning strainer screen	0.60 litres (0.65 US qt, 0.53 Imp qt)
	After disassembly	0.75 litres (0.80 US qt, 0.66 Imp qt)
Transmission Oil capacity	After draining	0.09 litres (0.10 US qt, 0.08 Imp qt)
	After disassembly	0.10 litres (0.11 US qt, 0.09 Imp qt)

Specifications

■ Bulbs

Headlight	LED
Brakelight/Taillight	12 V- 21/5 W
Front turn signal	12 V- 21 W x 2
Rear turn signal	12 V- 21 W x 2

■ Fuses

Main fuse	15 A
	7.5 A
Other fuse	40 A

■ Torque Specifications

Engine oil plug	20 N-m (2.0 kgf-m, 15 lbf-ft)
Engine oil drain bolt	24 N-m (2.4 kgf-m, 18 lbf-ft)

Warranty Policy (Valid in India only)

Honda Motorcycle & Scooter India (Pvt.) Ltd. (HMSI) gives the following warranty in respect of vehicle "**ACTIVA**" manufactured by them.

Proper care and precaution has been taken to ensure the best quality in respect of the material and workmanship in manufacturing of every vehicle.

HMSI would repair or replace at its discretion, those part(s) found to have manufacturing defects during examination. This repair or replacement of part(s) would be done free of charge at their authorised workshop, within a warranty period of 36 months from the date of sale or until the vehicle has covered 36000kms, whichever comes first.

Warranty claims in respect of proprietary parts like tyres and battery are warranted by their respective manufacturers and should be claimed on them directly by customer.

NOTE: Battery Warranty is applicable from 21 months from Date Of Charging at manufacturer or 18 Months from the Date Of Sale or 20000 Kms whichever is earlier.

In all such cases the decision of the respective manufacturer will be final and binding.

HMSI shall not be liable in any manner to replace them though their dealers will give full assistance in preferring such claims on their manufacturers.

HMSI undertake no liability in the matter of consequential loss or damage caused due to the failure of the parts. Delay, if any, at the repairing workshop in carrying out repair to vehicle shall not be a ground for extending the warranty period nor shall it give any right to the customer for claiming any compensation for damages.

HMSI reserves the right either to repair or replace the defective part.

Where a defective part can be replaced by part/s of alternative brand/s, which are normally used by HMSI in the course of manufacturing, HMSI reserves the right to carry out the replacement by a part or parts of any such alternative brands.

Warranty Policy (Valid in India Only)

This warranty and any claim arising there from is subject to Gurugram jurisdiction only.

No claim for exchange or repair can be considered unless the customer:

- a. Ensures that immediately upon discovery of the defect, he approaches any nearest authorised dealer of HMSI with the concerned vehicle and enables him to remove and dispatch the part/parts attributing to manufacturing defect to the company.
- b. Produces Owner's Manual in original, to enable that dealer to verify the details. It must be expressly understood that claims forwarded directly to us by the owner/customer will not be entertained at all and such defective part/parts thus forwarded by them will lie at our factory at their own risk, and this warranty shall not be enforceable.

Further this warranty is not applicable to:

1. Any vehicle on which any free and paid services has not been carried out, as per schedule given in Owner's Manual.
2. Normal maintenance operations like valve adjustment, cleaning of fuel system or such other adjustments.
3. HMSI does not warrant normal wear and tear items like Clutch Weight, Clutch Disc, Brake shoe, Brake Pads, Brake Disc, Drive belt, Drive Chain, Drive Chain Sprocket, Wheel Rim (in case of misalignment and bent), Bushes, Fasteners, Shims, Washers and Electrical items like Bulbs, Fuses, Rubber and Plastic Components like Grommets, O-Rings, Bellows, Packings, Gaskets, Oil Seals and Consumables like Fuel Filter, Air Cleaner Element, Engine Oil, Grease, Suspension Oil, and other items as specified by HMSI.
4. Fasteners and clips which needs replacement during maintenance/service will not be covered under warranty.

5. If there is any damage to the painted surface due to industrial pollution or other extraneous factors.
6. Any damage resulting from unavoidable natural disaster i.e fire, collision, earthquake, flood etc.
7. Any damage caused by exposure of the product to soot and smoke, chemical agents, bird-droppings, sea water, sea breeze, or other environmental phenomenon.
8. If there is any damage caused due to usage of improper oil/grease, non genuine parts.
9. For two-wheelers, which have been used for any commercial purposes as taxi etc.
10. For maintenance repairs required due to misuse while driving or due to adulteration of oil, petrol or due to bad road conditions.
11. Recommended fuel quality not used.
12. Parts of the vehicle that have been subjected to misuse, accident, negligent treatment or which have been used in conjunction with parts and an equipment not manufactured or recommended for use by HMSI if in the sole judgment of HMSI, such use prematurely affects the performance and reliability of the vehicle.
13. Parts of the vehicle that have been altered or modified or replaced in unauthorised manner, and which in the sole judgment of HMSI affect its performance and reliability.
14. The vehicle that has not been serviced by HMSI authorised dealer as per the service schedule or which have not been operated or maintained in accordance with instructions mentioned in the Owner's Manual.
15. The vehicles used for any competition or race and/or for attempting to set up any kind of record HMSI reserves the right to make any changes in design or to add any improvement on the vehicle at any time without incurring any obligations to install the same on a vehicle previously supplied and sold. Also the conditions of this warranty are subject to alteration without any notice.

Warranty Policy (Valid in India Only)

This warranty is entirely written warranty given by HMSI and no other person, including the dealer or its or his agent or employee is authorised to extend or enlarge this warranty.

This warranty is given in lieu of and excludes every condition or warranty whether statutory or otherwise not herein expressly set out.

EMISSION WARRANTY

Subject to other terms of the warranty policy and other conditions and obligations laid down hereunder, the manufacturer certifies that the components liable to affect the emission of the gaseous pollutants in the vehicle in normal use despite the use to which it may be subjected, comply with provisions of rule 115(2) of the Central Motor Vehicle Rules, 1989 and further warrants that if on examination by a service center duly authorized by the manufacturer, the vehicle is discovered to be failing to meet the emission standard as specified in the said rule,

the authorized service center shall take such corrective measures as may be necessary and shall at its sole discretion replace free of charge such components of emission control system as are specified in schedule.

A. Conditions

1. This warranty will be in addition to and run parallel to the product warranty given by the manufacturer and will apply to components as mentioned later. This warranty is applicable in Delhi, Mumbai, Kolkata and Chennai with effective from 1st July 2001. Other places when included will be covered under warranty accordingly.
2. The period of the vehicle's emission warranty will be determined starting from the date of the vehicle sale. The period of time and kilometers that are covered under the provisions of warranty may vary but should not be less than the minimum warranty period based on the vehicle category.

For a two-wheeler the emission warranty period is 30,000 kms or 3 years whichever is earlier.

3. Warranty claim for the components under Emission warranty will be admitted, for a prima facie examination, in the event of failure of the vehicle to meet the emission standard as specified in sub-rule (2) of Rule No 115 of the Central Motor vehicle Rules.
4. The warranty claim will be accepted only after the examinations carried out by Authorized Service Centers leads to a firm conclusion that none of the original settings have been tampered with and that the components has/have a manufacturing defect, and/or, that the vehicle is unable to meet the in-use emission standard, in spite of the vehicle being maintained and used in accordance with the instructions in the owner's manual.
5. The methods of examination to determine the warrantable condition of the components will be at the sole discretion of manufacturers and or their Authorized service centers and results of such examination will be final and binding. If, on examination, a warrantable condition is not established, the manufacturers will have to charge all, or part, of the cost of such examination.
6. In case of a vehicle in which the components covered under Emission warranty, the manufacturer will replace, at Authorized centers free of charge, the components which are covered, but the consumables as mentioned in Owner's Manual shall be charged as per actuals.
7. In case of a vehicle in which the components covered under Emission warranty or the associated parts are not independently replaceable on account of their being integral parts of a complete assembly, the manufacturer will have the sole discretion to replace either the entire assembly or by using some of the parts of the system through suitable repairs or modifications.

Warranty Policy (Valid in India Only)

8. Any consequential repairs or replacement of parts which may be found necessary to establish compliance to in-use emission standards, in addition to replacement of the parts covered under emission warranty, will not be made free of cost unless such parts are also found to be in a warrantable condition within the scope and limit of the product warranty. The consumables shall be charged as per actual during such repairs or replacement of parts.
9. All the parts removed for replacement under warranty will be the property of the manufacturer.
10. The manufacturer will not be responsible for the cost of transportation of the vehicle to the nearest Authorized Service center or any loss due to non-availability of the vehicle during the period of lodging of a warranty claim and examination by the manufacturer and repairs.
11. The manufacturer will not be responsible for any penalties that may be charged by statutory authorities on account of failure to comply with the in use emission standards.
12. Emission warranty will be applicable irrespective of the change of ownership of the vehicle provided all the conditions as laid down in this document are met from the date of original sale of the vehicle.
13. The emission warranty will be applicable only if:
 - a. Observes all the important instructions and any other precautions listed in the Owner's Manual for use of the vehicle.
 - b. Under all circumstances uses lubricants and fuel as recommended by manufacturer.
 - c. Regularly obtains and carries out maintenance in accordance with the manufacturers guidelines and enters the details in the Logbook.
 - d. Immediately approaches the nearest authorized service center upon discovery of failure to comply with the

in use emission standards in spite of having maintained and used the vehicle in accordance with the instructions in the Owner's Manual and having carried out such repairs and adjustments as may be required with a view to establish such compliance.

- e. Produces the 'Pollution Under Control' certificate valid for the period immediately preceding the test during which the failure is discovered, the test having been carried out either for obtaining a new certificate, or pursuant upon being directed by an officer as referred to in sub-rule(2) of Rule 116 of the Central Motor Vehicle Rules.
- f. Produces the Owner's Manual and Log book for verification details.
- g. Produces receipts covering maintenance of the vehicle as specified in the Owner's Manual from the date of original purchase of the vehicle.

h. Produces valid certificate of insurance and RTO registration.

14. Conditions under which warranty is not applicable:

A valid 'Pollution Under Control' certificate as described in customer obligation D(6) above is not produced.

A vehicle which is not serviced by Authorized service center as per the service schedule described in the maintenance chart given in the Owner's Manual.

A vehicle, which has been subjected to abnormal use, abuse, neglect and improper maintenance or has met with an accident. Use of replacement parts not specified and approved by the manufacturer.

A vehicle, or parts thereof, which has been altered, tampered with or modified or replaced in an unauthorized manner.

A vehicle on which the odometer is not functioning or the odometer has been changed/tampered with so that the actual mileage cannot be readily determined.

Warranty Policy (Valid in India Only)

A vehicle which has been used for competitions, races, rallies or for the purpose of establishing records.

Examination by the manufacturers or his Authorized Service Centers of the vehicle shows that any of the conditions stipulated in the Owner's Manual with regard to use and maintenance have been violated.

A vehicle, which has been run on, adulterated fuel, leaded fuel or lubricant or fuel/lubricants other than those specified by the manufacturer in the Owner's Manual with regard to use and maintenance have been violated.

SCOPE AND LIMITS

1. This emission warranty is in addition to product warranty and shall run parallel to the product warranty for the vehicle as per the scope and limit described in the Owner's Manual and all conditions described there in will apply in addition to those exclusively stipulated in this warranty.

2. The emission warranty covers only compliance with the emission standard as specified in the sub rule (2) of rule 115 of CMVR. It does not cover any other performance of these parts or routine test and consequent maintenance or adjustments to establish compliance to the in use emission standard as applicable to the state, in which the vehicle is registered and is in use.

The parts, which are covered under emission warranty, are throttle body, fuel injector, ignition coil, muffler etc.

NOTE: The emission warranty is applicable only when a customer enters into emission warranty contract.

- A**
Accessories.....12
Answer Back System.....34
- B**
Basic Operation Flow.....14
Battery.....56, 65
Brakes
 Brake Lever Freeplay.....77
 Shoe Wear.....82
Braking.....9
Bulb
 Brake/Tail Light.....104
 Front Turn Signal.....105
 Headlight.....104
 Rear Turn Signal.....105
- C**
Caring for Your Vehicle.....114
Catalytic Converter.....121
Compartment
 Document Bag.....48, 113
 Owner's Manual.....113
 Tools.....64
- Crankcase Breather.....84
- E**
Electrical Trouble.....103
Engine
 Number.....119
 Oil.....59, 73
 Starting.....37
Environment.....118
- F**
Frame Number.....119
Fuel
 Gauge.....18
 Recommended.....44
 Remaining.....18
 Tank Capacity.....44
Fuels Containing Alcohol.....120
Fuses.....59, 106
- G**
Gasohol.....120

H	
Headlight Aim	85
Headlight Dimmer Switch.....	20
Helmet Holders	47
High Beam Indicator	19
Honda SMART Key Battery	87
Honda SMART Key Indicator.....	19
Honda SMART Key System.....	25
Horn Button	20
I	
Ignition Key	109
Ignition Switch	21, 113
Indicators.....	19
Instruments.....	18
K	
Keys.....	109
L	
Load Limits	13
Loading Guidelines	13
M	
Maintenance	
Fundamentals.....	55
Importance	51
Safety.....	51
Schedule.....	52
Maximum Weight Limit.....	13, 122
Modifications.....	12
O	
Odometer	18, 113
Oil	
Engine	59, 73
P	
Parking.....	10
Parts Location.....	16
Petrol	11, 44, 122
PGM-FI (Programmed Fuel Injection)	
Malfunction Indicator Lamp (MIL).....	19, 92
Protective Apparel.....	8

R	
Recommended	
Fuel.....	44
Oil.....	59
Refueling.....	44
Removal	
Battery.....	65
Battery Lid.....	66
Body Cover.....	67
Clip.....	68
Headlight Case.....	69
Riding Precautions.....	9
S	
Safety Precautions.....	8
Seat.....	46
Serial Numbers.....	119
Shutter.....	24
Spark Plug.....	71
Specifications.....	122
Speedometer.....	18
Start Button.....	20
Starting the Engine.....	37
Starting the Vehicle.....	42
Steering Lock.....	22
Storage Equipment.....	46
Storing Your Vehicle.....	117
Switches.....	20
T	
Throttle.....	83
Tools.....	64
Transporting Your Vehicle.....	117
Troubleshooting.....	90
Turn signal indicators.....	19
Tyres	
Air Pressure.....	61, 123
Puncture.....	102
Replacing.....	61, 123
W	
Warning Indicator On or Flashing.....	92
Warranty Policy.....	125
Washing Your Vehicle.....	114