

This manual should be considered a permanent part of the vehicle and should remain with the vehicle when it is resold.

This publication includes the latest production information available before printing. Honda Motor Co., Ltd. reserves the right to make changes at any time without notice and without incurring any obligation.

No part of this publication may be reproduced without written permission.

The vehicle pictured in this owner's manual may not match your actual vehicle.

For any query or assistance, please call Customer care number:
1800 103 3434 (Toll free)

Welcome

Congratulations on your purchase of a new Honda vehicle. Your selection of a Honda makes you part of a worldwide family of satisfied customers who appreciate Honda's reputation for building quality into every product.

To ensure your safety and riding pleasure:

- Read this owner's manual carefully.
- Follow all recommendations and procedures contained in this manual.
- Pay close attention to safety messages contained in this manual and on the vehicle.

- The following codes in this manual indicate the country.
- The illustrations here in are based on the CBF125M VII ID type.

Country Codes

| Code | Country |
|--------------------------------|---------|
| CBF125M | |
| III ID, IV ID, VII ID, VIII ID | India |

A Few Words About Safety

Your safety, and the safety of others, is very important. Operating this vehicle safely is an important responsibility.

To help you make informed decisions about safety, we have provided operating procedures and other information on safety labels and in this manual. This information alerts you to potential hazards that could hurt you or others.

Of course, it is not practical or possible to warn you about all hazards associated with operating or maintaining a vehicle. You must use your own good judgement.

You will find important safety information in a variety of forms, including:

- Safety labels on the vehicle
- Safety Messages preceded by a safety alert symbol  and one of three signal words: DANGER, WARNING, or CAUTION.

These signal words mean:

DANGER

You **WILL** be **KILLED** or **SERIOUSLY HURT** if you don't follow instructions.

WARNING

You **CAN** be **KILLED** or **SERIOUSLY HURT** if you don't follow instructions.

CAUTION

You **CAN** be **HURT** if you don't follow instructions.

Other important information is provided under the following titles:

NOTICE Information to help you avoid damage to your vehicle, other property, or the environment.

Contents

Vehicle Safety P. 2

Operation Guide P. 14

Maintenance P. 37

Troubleshooting P. 87

Information P. 104

Specifications P. 116

Warranty Policy P. 119

Index P. 127

Vehicle Safety

This section contains important information for safe riding of your vehicle.
Please read this section carefully.

| | |
|--|-------|
| Safety Guidelines | P. 3 |
| Image Labels | P. 6 |
| Safety Precautions | P. 8 |
| Riding Precautions | P. 9 |
| Accessories & Modifications | P. 12 |
| Loading | P. 13 |

Safety Guidelines

Follow these guidelines to enhance your safety:

- Perform all routine and regular inspections specified in this manual.
- Stop the engine and keep sparks and flame away before filling the fuel tank.
- Do not run the engine in enclosed or partly enclosed areas. Carbon monoxide in exhaust gases is toxic and can kill you.

Always Wear a Helmet

It's a proven fact: helmets and protective apparel significantly reduce the number and severity of head and other injuries. So always wear an approved helmet and protective apparel. 📄P.8

Before Riding

Make sure that you are physically fit, mentally focused and free of alcohol and drugs. Check

that you and your passenger are both wearing an approved helmet and protective apparel. Instruct your passenger on holding onto the grab rail or your waist, leaning with you in turns, and keeping their feet on the footpegs, even when the vehicle is stopped.

Take Time to Learn & Practice

Even if you have ridden other vehicle, practice riding in a safe area to become familiar with how this vehicle works and handles, and to become accustomed to the vehicle's size and weight.

Ride Defensively

Always pay attention to other vehicles around you, and do not assume that other drivers see you. Be prepared to stop quickly or perform an evasive maneuver.

Safety Guidelines

Make Yourself Easy to See

Make yourself more visible, especially at night, by wearing bright reflective clothing, positioning yourself so other drivers can see you, signaling before turning or changing lanes, and using your horn when necessary.

Ride within Your Limits

Never ride beyond your personal abilities or faster than conditions warrant. Fatigue and inattention can impair your ability to use good judgement and ride safely.

Don't Drink and Ride

Alcohol and riding don't mix. Even one alcoholic drink can reduce your ability to respond to changing conditions, and your reaction time gets worse with every additional drink. Don't drink and ride, and don't let your friends drink and ride either.

Keep Your Honda in Safe Condition

It's important to keep your vehicle properly maintained and in safe riding condition. Inspect your vehicle before every ride and perform all recommended maintenance. Never exceed load limits (➤P.13), and do not modify your vehicle or install accessories that would make your vehicle unsafe (➤P.12).

If You are Involved in a Crash

Personal safety is your first priority. If you or anyone else has been injured, take time to assess the severity of the injuries and whether it is safe to continue riding. Call for emergency assistance if needed. Also follow applicable laws and regulations if another person or vehicle is involved in the crash.

If you decide to continue riding, first turn the ignition switch to the OFF position, and evaluate the condition of your vehicle. Inspect for fluid leaks, check the tightness of critical nuts and

bolts, and check the handlebar, control levers, brakes, and wheels. Ride slowly and cautiously. Your vehicle may have suffered damage that is not immediately apparent. Have your vehicle thoroughly checked at a qualified service facility as soon as possible.

Carbon Monoxide Hazard

Exhaust contains poisonous carbon monoxide, a colourless, odorless gas. Breathing carbon monoxide can cause loss of consciousness and may lead to death.

If you run the engine in confined or even partly enclosed area, the air you breathe could contain a dangerous amount of carbon monoxide.

Never run your vehicle inside a garage or other enclosure.

WARNING

Running the engine of your vehicle while in an enclosed or even partially enclosed area can cause a rapid build-up of toxic carbon monoxide gas.

Breathing this colourless, odorless gas can quickly cause unconsciousness and lead to death.

Only run your vehicle's engine when it is located in a well ventilated area outdoors.

Image Labels

The following pages describe the label meanings. Some labels warn you of potential hazards that could cause serious injury. Others provide important safety information. Read this information carefully and don't remove the labels.

If a label comes off or becomes hard to read, contact your dealer for a replacement.

There is a specific symbol on each label. The meanings of each symbol and label are as follows.



Read instructions contained in Owner's Manual carefully.



Read instructions contained in Shop Manual carefully. In the interest of safety, take the vehicle to be serviced only by your dealer.

DANGER (with RED background)

You **WILL** be **KILLED** or **SERIOUSLY HURT** if you don't follow instructions.

WARNING (with ORANGE background)

You **CAN** be **KILLED** or **SERIOUSLY HURT** if you don't follow instructions.

CAUTION (with YELLOW background)

You **CAN** be **HURT** if you don't follow instructions.



**BATTERY LABEL
DANGER**

- Keep flame and spark away from the battery. Battery produce explosive gas that can cause explosion.
- Wear the eye protection and rubber gloves when handling the battery, or you can get burned or lose your eyesight by the battery electrolyte.
- Do not allow children and other people to touch a battery unless they understand proper handling and hazards of the battery very well.
- Handle the battery electrolyte with extreme care as it contains dilute sulfuric acid. Contact with your skin or eyes can burn you or cause loss of your eyesight.
- Read this manual carefully and understand it before handling the battery. Neglect of the instructions can cause personal injury and damage to the vehicle.
- Do not use a battery with the electrolyte at or below the lower level mark. It can explode causing serious injury.

Safety Precautions

Safety Precautions

- Ride cautiously and keep your hands on the handlebar and feet on the footpegs.
- Keep passenger's hands onto the grab rail or your waist, passenger's feet on the footpegs while riding.
- Always consider the safety of your passenger, as well as other drivers and riders.

Protective Apparel

Make sure that you and any passenger are wearing an approved helmet, eye protection, and high-visibility protective clothing. Ride defensively in response to weather and road conditions. Be sure to avoid loose clothes that could get caught on any part of your vehicle.

| Helmet

Safety-standard certified, high-visibility, correct size for your head

- Must fit comfortably but securely, with the chin strap fastened.

- Face shield with unobstructed field of vision or other approved eye protection

WARNING

Not wearing a helmet increases the chance of serious injury or death in a crash.

Make sure that you and any passenger always wear an approved helmet and protective apparel.

| Gloves

Full-finger leather gloves with high abrasion resistance

| Boots or Riding Shoes

Sturdy boots with non-slip soles and ankle protection

| Jacket and Trousers

Protective, highly visible, long-sleeved jacket and durable trousers for riding (or a protective suit)

Riding Precautions

Running-in Period

During the first 500 km (300 miles) of running, follow these guidelines to ensure your vehicle's future reliability and performance.

- Avoid full-throttle starts and rapid acceleration.
- Avoid hard braking and rapid down-shifts.
- Ride conservatively.

Brakes

Observe the following guidelines:

- Avoid excessively hard braking and down-shifting.
 - ▶ Sudden braking can reduce the vehicle's stability.
 - ▶ Where possible, reduce speed before turning; otherwise you risk sliding out.

- Exercise caution on low traction surfaces.
 - ▶ The tyres slip more easily on such surfaces, and braking distances are longer.
- Avoid continuous braking.
 - ▶ Repeated braking, such as when descending long, steep slopes can seriously overheat the brakes, reducing their effectiveness. Use engine braking with intermittent use of the brakes to reduce speed.
- For full braking effectiveness, operate both the front and rear brakes together.

Combi Brake

Your vehicle is equipped with a brake system that distributes the braking force between the front and rear brakes.

The distribution of the braking force applied to the front and rear brakes when operating the lever only and when operating the pedal only is different.

For full braking effectiveness, operate both the front and rear brakes together.

Riding Precautions

| Engine Braking

Engine braking helps slow your vehicle down when you release the throttle. For further slowing action, downshift to a lower gear. Use engine braking with intermittent use of the brakes to reduce speed when descending long, steep slopes.

| Wet or Rainy Conditions

Road surfaces are slippery when wet, and wet brakes further reduce braking efficiency. Exercise extra caution when braking in wet conditions.

If the brakes get wet, apply the brakes while riding at low speed to help them dry.

Parking

- Park on a firm, level surface.
- If you must park on a slight incline or loose surface, park so that the vehicle cannot move or fall over.
- Make sure that high-temperature parts cannot come into contact with flammable materials.
- Do not touch the engine, muffler, brakes and other high-temperature parts until they cool down.
- To reduce the likelihood of theft, always lock the handlebar and remove the key when leaving the vehicle unattended.

Use of an anti-theft device is also recommended.

| Parking with the Side Stand or Centre Stand

1. Stop the engine.
2. **Using the side stand**

Push the side stand down.

Slowly lean the vehicle to the left until its weight rests on the side stand.

Turn the handlebar fully to the left.

- ▶ Turning the handlebar to the right reduces stability and may cause the vehicle to fall.

Using the centre stand

To lower the centre stand, stand on the left side of the vehicle.

Hold the left handle grip and the grab rail.

Press down on the tip of the centre stand with your right foot and, simultaneously, pull up and back. Turn the handlebar fully to the left or right.

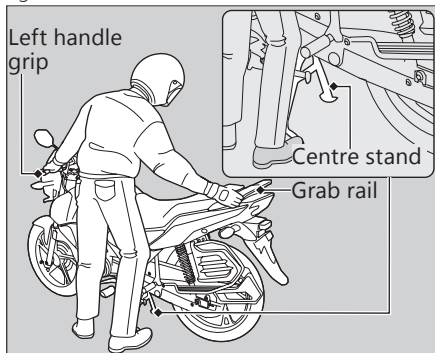

3. Turn the ignition switch to the LOCK position and remove the key. ➤P.29

Refuelling and Fuel Guidelines

Follow these guidelines to protect the engine, fuel system and catalytic converter:

- Use only unleaded petrol.
- Use recommended octane number. Using lower octane petrol will result in decreased engine performance.
- Do not use fuels containing a high concentration of alcohol. ➤P.114
- Do not use stale or contaminated petrol or an oil/petrol mixture.
- Avoid getting dirt or water in the fuel tank.

Accessories & Modifications

We strongly advise that you do not add any accessories that were not specifically designed for your vehicle by Honda or make modifications to your vehicle from its original design. Doing so can make it unsafe.

Modifying your vehicle may also void your warranty and make your vehicle illegal to operate on public roads. Before deciding to install accessories on your vehicle be certain the modification is safe and legal.

WARNING

Improper accessories or modifications can cause a crash in which you can be seriously hurt or killed.

Follow all instructions in this owner's manual regarding accessories and modifications.

Do not pull a trailer with, or attach a sidecar to, your vehicle. Your vehicle was not designed for these attachments, and their use can seriously impair your vehicle's handling.

Loading

- Carrying extra weight affects your vehicle's handling, braking and stability.
Always ride at a safe speed for the load you are carrying.
- Avoid carrying an excessive load and keep within specified load limits.
Maximum weight capacity ➤ P.116
- Tie all luggage securely, evenly balanced and close to the centre of the vehicle.
- Do not place objects near the lights or the muffler.

WARNING

Overloading or improper loading can cause a crash and you can be seriously hurt or killed.

Follow all load limits and other loading guidelines in this manual.



Basic Operation Flow

| Pre-ride Inspection P. 42

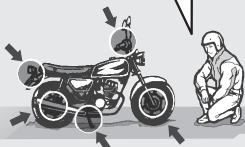
Carefully inspect your vehicle to make sure that it is safe to ride.



How to use basic features.

- Instruments  P. 18
- Indicators  P. 25
- Switches  P. 27
- Steering Lock  P. 29

| Acceleration

Apply throttle gradually.
Obey the speed limit.



| Shift Change P. 33

| Starting the Engine P. 30

Start and warm the engine.
Avoid revving the engine.



| Starting the Vehicle

Before pulling away, indicate your direction with the turn signal switch, and check for oncoming traffic.



| Braking

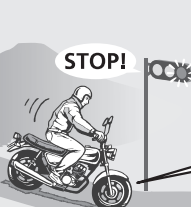

STOP!

Close the throttle and apply the front and rear brakes together.
 ▶ The brakelight will indicate that you have applied the brakes.

| Stopping

If pulling off the road, signal early enough to show traffic that you are pulling over, and pull over smoothly.



| Turning Corners

Do your braking before entering corners.

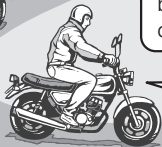

Gradually reapply throttle when exiting turn.

| Parking → P. 10

Park on a firm level surface. Use the stand, and lock the steering.



| Refuelling → P. 34



Parts Location

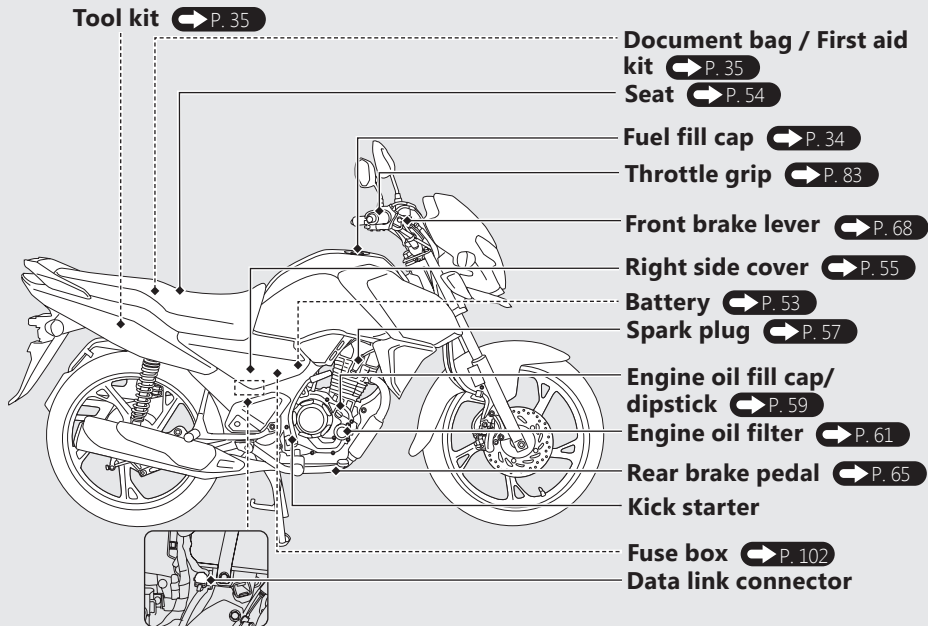

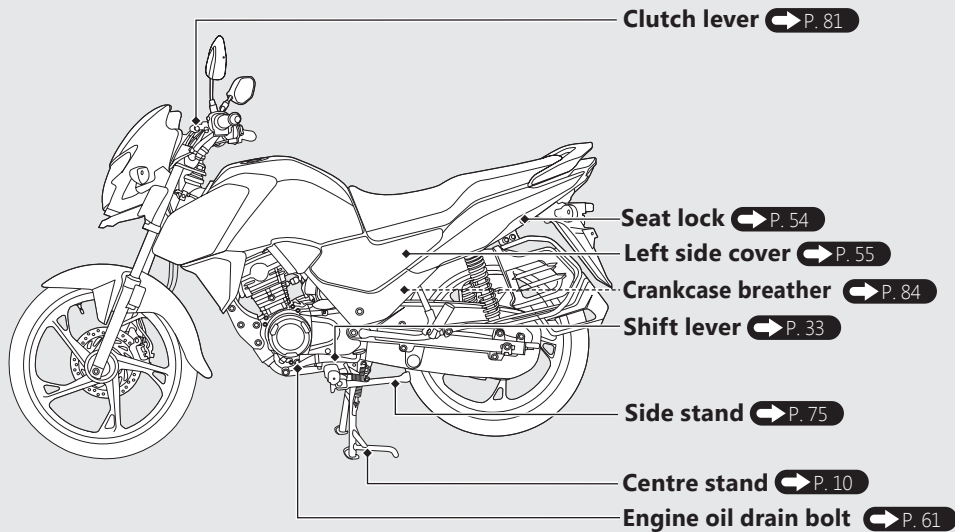

Instruments

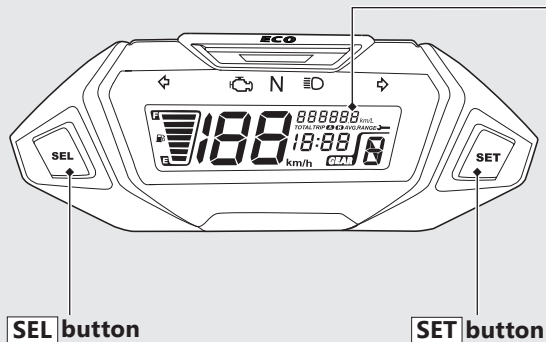

Display Check

When the ignition switch is turned on, all the mode and digital segments will show. If any part of these displays does not come on when it should, have your dealer check for problems.

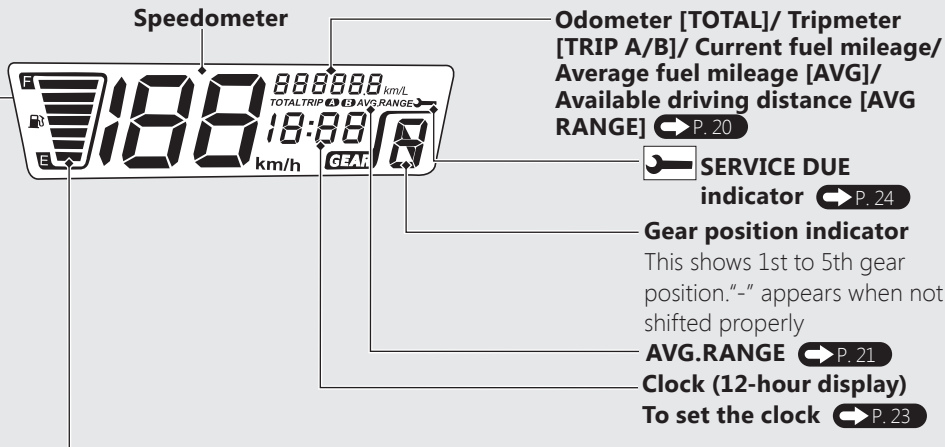

Fuel gauge

Remaining fuel when only 1st (E) segment starts flashing:
approximately 0.8 litres (0.21 US gal, 0.18 Imp gal)

If the fuel gauge indicator flashes in a repeat pattern or turns off: [➡ P. 90](#)

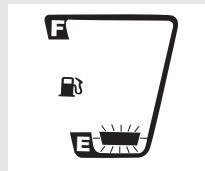

Instruments (Continued)

Odometer [TOTAL]/ Tripmeter [TRIP A/B]/ Current fuel mileage/ Average fuel mileage [AVG]/ Available driving distance [AVG RANGE]

SEL button selects the odometer, tripmeter, current fuel mileage, average fuel mileage and available driving distance.

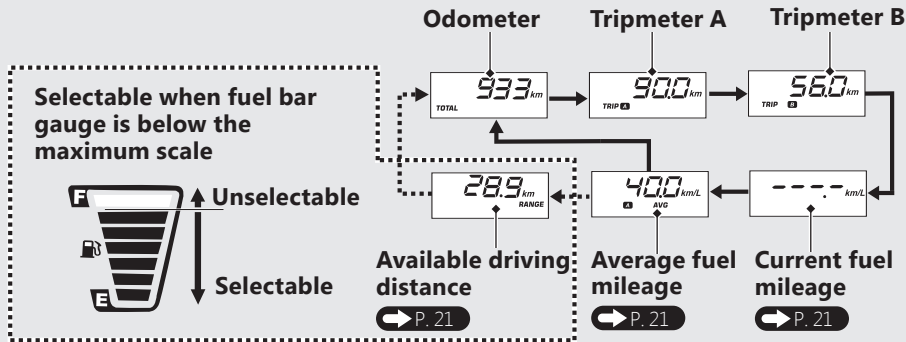

- Odometer: Total distance ridden.
- Tripmeter [A/B]: Distance ridden since tripmeter was reset.
 - ▶ To reset the tripmeter. **➡ P. 22**

- Current fuel mileage: Displays instant fuel mileage.
If your speed is less than 5 ± 2 km/h or immediately after ignition switch is turned to ON, "--.-" is displayed.
When "--.-" is displayed on other cases, go to your dealer for service.
- Average fuel mileage: Displays average fuel mileage since tripmeter A was reset.
It displays "--.-" after resetting tripmeter A. When "--.-" is displayed in other cases, go to your dealer for service.
- Available driving distance: (Selectable when the fuel gauge is displaying fuel quantity below maximum scale)
Displays the estimated distance you can travel on remaining fuel.
The indicated available driving distance is calculated based on the driving conditions, and the indicated figure may not be the actual available distance.
When the calculated distance is below 5 km (3 mile) or the amount of remaining fuel is below 1.0 L (0.26 US gal, 0.22 Imp gal): "---" is displayed.
For a while after resetting the tripmeter A: "--.-" is displayed.
When "---" is displayed except for the above-mentioned cases, go to your dealer for service.

Instruments (Continued)

To reset the tripmeter, current fuel mileage, average fuel mileage and available driving distance

- To reset tripmeter A, current fuel mileage, average fuel mileage and available driving distance together, press and hold **SET** button with tripmeter A displayed.

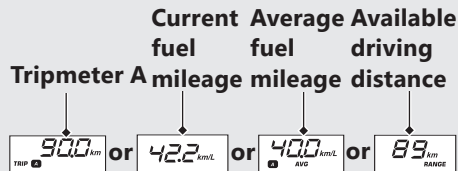

- When they are reset, "0.0" is displayed at each indication.

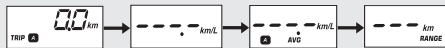

- Then, the display returns to the last selected indication.



- To reset tripmeter B, Press and hold SET button with tripmeter B displayed.

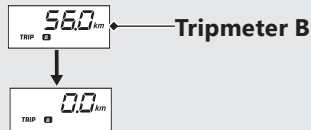

Clock Setting:

- 1 Turn the ignition switch to the ON position.
- 2 With odometer (TOTAL) displayed, press and hold the **SEL** and **SET** button until ECO indicator  P.26 starts flashing.
- 3 Press **SET** button. The hour digits start flashing.



- 4 Press the **SEL** button until the desired hour is displayed.
 - ▶ Hour will advance by one hour, each time **SEL** button is pressed. Press and hold to advance the hour fast.



- 5 Press the **SET** button. The minute digits start flashing.



- 6 Press **SEL** button until the desired minute is displayed.
 - ▶ Minute will advance by one minute, each time **SEL** button is pressed. Press and hold to advance the minute fast.



- 7 Press the **SET** button. The clock is set.
 - ▶ The time can also be set by turning the ignition switch off.
 - ▶ The display will stop flashing automatically and the adjustment will be cancelled if the button is not pressed for about 30 seconds.

NOTICE

The clock will be reset "1:00" if the battery is disconnected.

Instruments *(Continued)*

SERVICE DUE indicator

When odometer reading reaches specified distance then service due indicator light blinks upto service limit (kms) and then light glows continuously.

SERVICE DUE indicator lighting pattern understanding:

Blinking:

- ▶ Blinking of service due indicator indicates that your vehicle has reached the specified distance for service hence kindly visit your nearest Honda dealer for vehicle service.

Continuous glow:

- ▶ Indicate that your vehicle has crossed the specified distance for Service.

Immediately visit Honda dealer for vehicle service.

First blinking of service due indicator will start 250 km before first service (as per specified distance) of the vehicle.

Second blinking of service due indicator will start 500 kms before second service (as per specified distance) of the vehicle and later same pattern will continue for every next service.

Service due indicator will continuous glow if service of the vehicle is not done as per the specified distance mentioned in maintenance schedule.

NOTICE

Service due indicator blinking / continuous glow is an indication for vehicle service due which is based on distance (Kms) covered by the vehicle however every service schedule is to be followed as per the maintenance schedule with respect to days or kms covered (whichever comes first)

If your vehicle is serviced before the specified distance as mentioned in maintenance schedule ➔P.40, in that case service due indicator will start blinking, whenever your vehicle reach specified kilometer.

Kindly visit your Honda dealer for service due indicator resetting.

Indicators

If one of these indicators does not come on when it should, have your dealer check for problems.

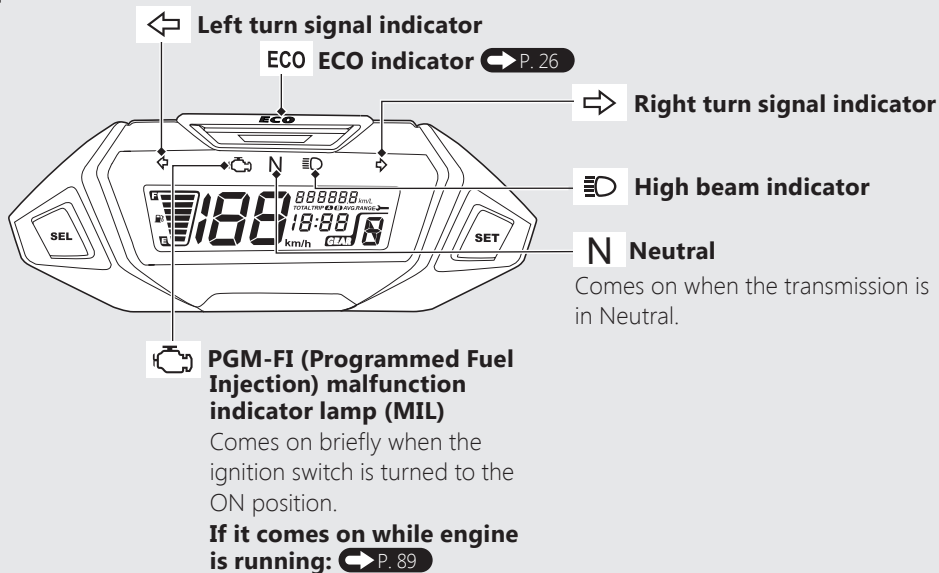

Indicators (Continued)

ECO indicator

When fuel consumption improves the ECO indicator will come on.

- ▶ When the motorcycle comes to a stop, the ECO indicator will turn off.

Activate or deactivate the indicator:

- 1 Turn the ignition switch to the ON position.
- 2 With odometer (TOTAL) displayed, press and hold the **SEL** and **SET** button until ECO indicator starts flashing.
- 3 Press **SEL** button to select "ON" (activate) or "OFF" (deactivate).



- 4 To set the desired option, press **SET** button. The hour digits start flashing.
- 5 Press **SET** button. The minute digits start flashing.
- 6 Press **SET** button. The minute digits stop flashing.
- 7 The ECO indicator is set.

Switches

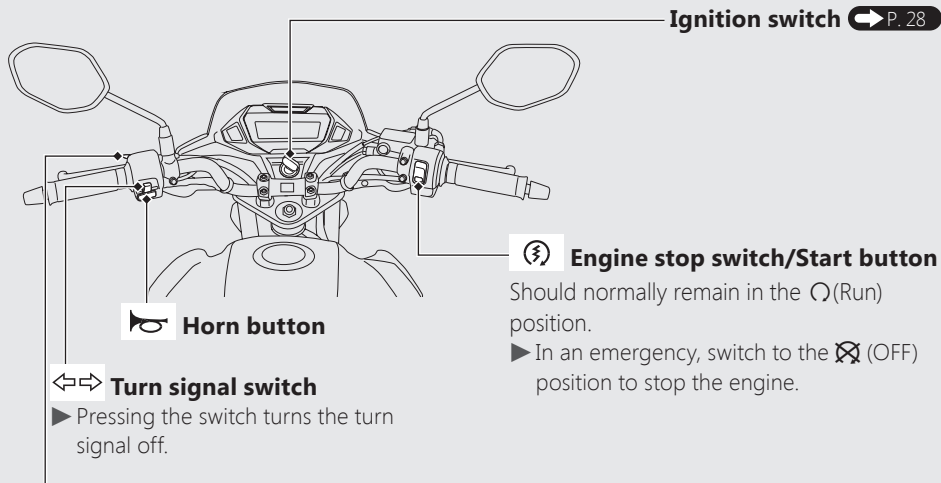

Headlight dimmer/ passing light control switch

- : High beam
- : Low beam
- : Flashes the high beam headlight

Switches *(Continued)*

Ignition switch

Switches the electrical system on/off, locks the steering.

- ▶ Key can be removed when in the OFF or LOCK position.

Steering Lock:  P. 29

ON ———
Turns electrical system on for starting/riding.

OFF ———
Turns engine off.

LOCK ———
Locks steering.

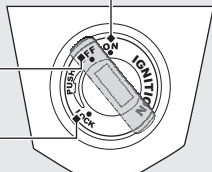

Steering Lock

Lock the steering when parking to help prevent theft.

A U-shaped wheel lock or similar device is also recommended.

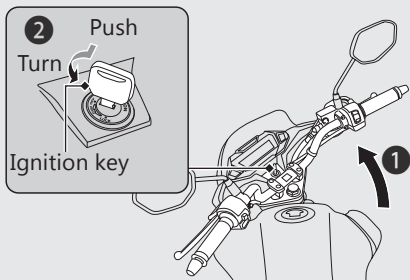

Locking

- 1 Turn the handlebar all the way to the left or right.
- 2 Push the key down, and turn the ignition switch to the LOCK position.
 - ▶ Jiggle the handlebar if the lock is difficult to engage.
- 3 Remove the key.

Unlocking

Insert the key, push it in, and turn the ignition switch to the OFF position.

Starting the Engine

Start your engine using the following procedure, regardless of whether the engine is cold or warm.

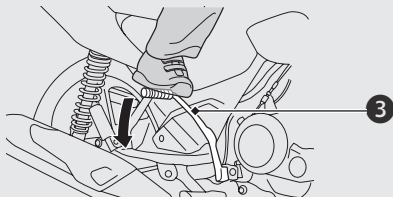
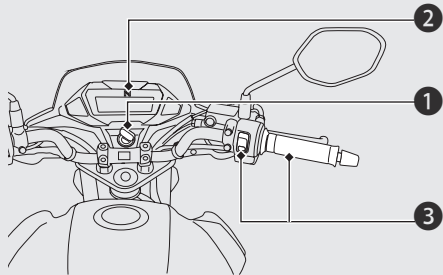

NOTICE

- If the engine does not start within 5 seconds, turn the ignition switch to the OFF position and wait 10 seconds before trying to start the engine again to recover battery voltage.
- Extended fast idling and revving the engine can damage the engine, and the exhaust system.
- Do not operate the kickstarter while the engine is running as engine damage could result. Do not apply excessive force on the kickstarter.
- Fold up the kickstarter after the kickstarter is return to the pedal stop.

Consult your dealer for advice if you plan to ride your vehicle at an altitude above 2,500 m (8,000 feet).

NOTICE

- If the vehicle is transported to a place 2,000 m (6,500 feet) higher or lower than the start point, you may not be able to achieve sufficient engine performance at the new altitude. Consult your dealer before transporting your vehicle.

- 1 Turn the ignition switch to the ON position.
- 2 Shift the transmission to Neutral (**N** indicator to come on)

3 Using the start button

With the throttle completely closed, press the start button.

Using the kickstarter

With the throttle completely closed, operate the kickstarter starting from the top of the stroke, kick through to the bottom with a rapid, continuous motion.

- 4 Warm up the engine by opening and closing the throttle slightly.

If you cannot start the engine:

Open the throttle slightly (about 3 mm, without freeplay).

About 3 mm without freeplay

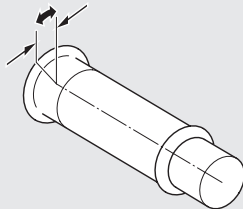

If the engine does not start:

Using the start button

- 1 Open the throttle fully and press the start button for 5 seconds.
- 2 Repeat the starting procedure.
- 3 If the engine starts, open the throttle slightly if idling is unstable.

Starting the Engine *(Continued)*

- ④ If the engine does not start, wait for 10 seconds, before trying steps ① & ② again.

Using the kickstarter

- ① Turn the ignition switch to OFF.
- ② Open the throttle fully and crank the engine several times with the kickstarter.
- ③ Turn the ignition switch to ON.
- ④ Repeat the starting procedure.
- ⑤ If engine start, open the throttle slightly if the idling is unstable.
- ⑥ If engine does not start, try steps ①-④ again.

If Engine Will Not Start  P. 88

Shifting Gears

Your vehicle transmission has 5 forward gears in a one-down, four-up shift pattern when you shift with your toe.

You can also shift to a higher gear by depressing the shift lever with your heel.

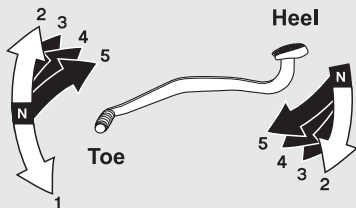

Refuelling

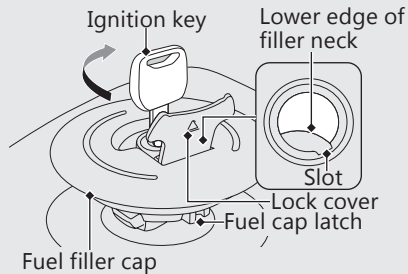

Do not fill with fuel above the lower edge of the filler neck.

Fuel type: Unleaded petrol only

Fuel octane number: Your vehicle is designed to use Research Octane Number (RON) 90 or higher.

Tank capacity: 10.5 litres (2.77 US gal, 2.30 Imp gal)

Refuelling and Fuel Guidelines ➔ P. 11
Opening the Fuel Fill Cap

Lift up the lock cover, insert the ignition key,

and turn it clockwise to open the cap.

Closing the Fuel Fill Cap

- 1 After refuelling, align the fuel cap latch with the slot in the filler neck. Push the fuel fill cap into the filler neck until it snaps closed and locks.
 - ▶ The key cannot be removed if the fuel fill cap is not locked.
- 2 Remove the key and close the lock cover.

⚠ WARNING

Petrol is highly flammable and explosive. You can be burned or seriously injured when handling fuel.

- Stop the engine, and keep heat, sparks, and flame away.
- Handle fuel only outdoors.
- Wipe up spills immediately.

Storage Equipment

Tool Kit/ Document Bag/ First Aid Kit

Tool kit and first aid kit are located under the seat. Document bag is located under side of the seat.

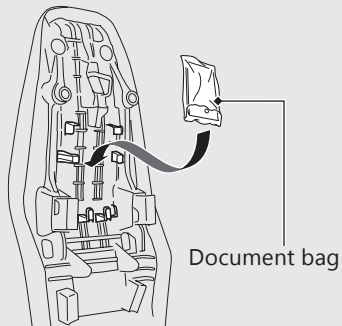
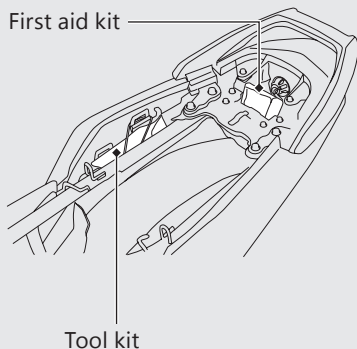

Removing the seat  P. 54

Helmet holder

The helmet holders are located under the seat of the motorcycle.

- ▶ Use the helmet holder only when parked.

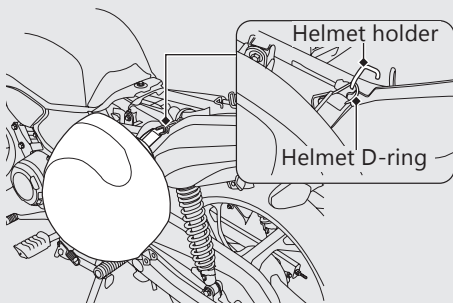

⚠ WARNING

Riding with a helmet attached to the holder can interfere with your ability to safely operate the vehicle and could lead to a crash in which you can be seriously hurt or killed.

Use the helmet holder only while parked. Do not ride with a helmet secured by the holder.

Maintenance

Please read "Importance of Maintenance" and "Maintenance Fundamentals" carefully before attempting any maintenance. Refer to "Specifications" for service data.

| | | | |
|--|------|------------------------------------|------|
| Importance of Maintenance | P.38 | Side Stand | P.75 |
| Maintenance Schedule | P.39 | Drive Chain | P.76 |
| Maintenance Fundamentals | P.42 | Clutch | P.81 |
| Tool | P.52 | Throttle | P.83 |
| Removing & Installing Body Components | P.53 | Crankcase Breather | P.84 |
| Battery..... | P.53 | Other Adjustments | P.85 |
| Drive Chain Case..... | P.54 | Adjusting the Headlight Aim..... | P.85 |
| Seat..... | P.55 | Adjusting the Rear Suspension..... | P.86 |
| Side Cover..... | P.56 | | |
| Spark Plug | P.57 | | |
| Engine Oil | P.59 | | |
| Brakes | P.63 | | |

Importance of Maintenance

Importance of Maintenance

Keeping your vehicle well-maintained is absolutely essential to your safety and to protect your investment, obtain maximum performance, avoid breakdowns, and reduce air pollution. Maintenance is the owner's responsibility. Be sure to inspect your vehicle before each ride, and perform the periodic checks specified in the Maintenance Schedule. ➔ P. 39

WARNING

Improperly maintaining your vehicle or failing to correct a problem before you ride can cause a crash in which you can be seriously hurt or killed.

Always follow the inspection and maintenance recommendations and schedules in this owner's manual.

Maintenance Safety

Always read the maintenance instructions before you begin each task, and make sure that you have the tools, parts, and skills required. We cannot warn you of every conceivable hazard that can arise in performing maintenance. Only you can decide whether or not you should perform a given task.

Follow these guidelines when performing maintenance.

- Stop the engine and remove the key.
- Place your vehicle on a firm, level surface using the side stand, centre stand or a maintenance stand to provide support.
- Allow the engine, muffler, brakes, and other high-temperature parts to cool before servicing as you can get burned.
- Run the engine only when instructed, and do so in a well-ventilated area.

Maintenance Schedule

The maintenance schedule specifies the maintenance requirements necessary to ensure safe, dependable performance, and proper emission control.







Maintenance work should be performed in accordance with Honda's standards and specifications by properly trained and equipped technicians. Your dealer meets all of these requirements. Keep an accurate record of maintenance to help ensure that your vehicle is properly maintained.

Make sure that whomever performs the maintenance completes this record.



All scheduled maintenance is considered a normal owner operating cost and will be charged to you by your dealer. Retain all receipts. If you sell the vehicle, these receipts should be transferred with the vehicle to the new owner.

Honda recommends that your dealer should road test your vehicle after each periodic maintenance is carried out.

Maintenance Schedule





































































































| Items | Pre-ride Check ▶P.42 | Frequency *1 | | | | | | | | Annual Check | Regular Replace | Refer to page |
|-------------------------------------|---|--------------|-----|------------------|----|----|----|----|----|--------------|-----------------|---------------|
| | | × 1,000 km | 1 | 6 | 12 | 18 | 24 | 30 | 36 | | | |
| | | × 1,000 mi | 0.6 | 4 | 8 | 12 | 16 | 20 | 24 | | | |
| | | Months | 1 | 6 | 12 | 18 | 24 | 30 | 36 | | | |
| Fuel Line |  | | | I | I | I | I | I | I | I | | - |
| Fuel Level | | I | | | | | | | | | | - |
| Throttle Operation |  | I | | I | I | I | I | I | I | I | | 83 |
| Air Cleaner *2 |  | | | | | R | | | | R | | 51 |
| Crankcase Breather*3 | | | | C | C | C | C | C | C | C | | 84 |
| Spark Plug | | | | I | R | I | R | I | R | | | 57 |
| Valve Clearance |  | | | I | I | I | I | I | I | | | - |
| Engine Oil | | I | | R | R | R | R | R | R | R | R | 59 |
| Engine Oil filter | | | | | | R | | | R | | | 61 |
| Engine Idle Speed |  | | | I | I | I | I | I | I | I | | - |
| Evaporative Emission Control System |  | | | | | | I | | | I | | - |
| Drive Chain | | I | | 1000 km (600mi): | | | | | I | L | | 76 |

Maintenance Level

-  : Intermediate. We recommend service by your dealer, unless you have the necessary tools and are mechanically skilled. Procedures are provided in an official Honda Shop Manual.
-  : Technical. In the interest of safety, have your vehicle serviced by your dealer.

Maintenance Legend

- I** : Inspect (clean, adjust, lubricate, or replace, if necessary)
- R** : Replace
- C** : Clean
- L** : Lubricate

| Items | Pre-ride Check  | Frequency *1 | | | | | | | | Annual Check | Regular Replace | Refer to page |
|------------------------------------|--|---|---|---|---|---|---|---|---|---|--------------------|---------------------|
| | | × 1,000 km | 1 | 6 | 12 | 18 | 24 | 30 | 36 | | | |
| | | × 1,000 mi | 0.6 | 4 | 8 | 12 | 16 | 20 | 24 | | | |
| | | Months | 1 | 6 | 12 | 18 | 24 | 30 | 36 | | | |
| Drive Chain Slider | | | |  |  |  |  |  |  | | | 80 |
| Brake Fluid*4 (III & VII ID) |  | | |  |  |  |  |  |  |  | 2 Years | 63 |
| Brake Shoe Wear (IV & VIII ID) |  | | |  |  |  |  |  |  |  | | 73 |
| Brake Shoe/Pad Wear (III & VII ID) |  | | |  |  |  |  |  |  |  | | 67,64 |
| Brake System |  | |  |  |  |  |  |  |  |  | | 63 |
| Brakelight Switch | | | |  |  |  |  |  |  |  | | - |
| Headlight Aim | | | |  |  |  |  |  |  |  | | 85 |
| Lights/Horn |  | | | | | | | | | | | - |
| Engine Stop Switch |  | | | | | | | | | | | - |
| Clutch System |  | |  |  |  |  |  |  |  |  | | 81 |
| Side Stand | | | |  |  |  |  |  |  |  | | 75 |
| Suspension |  | | |  |  |  |  |  |  |  | | 86 |
| Nuts, Bolts, Fasteners |  | |  | |  | |  | |  |  | | - |
| Wheels/Tires |  |  | |  |  |  |  |  |  |  | | 49 |
| Steering Head Bearings |  | | | |  | |  | |  |  | | - |

Service according to odometer reading or months, whichever is earlier.

Notes:

- *1 : At higher odometer readings, repeat at the frequency interval established here.
- *2 : Service more frequently when riding in unusually wet or dusty areas.
- *3 : Service more frequently when riding in rain or at full throttle.
- *4 : Replacement requires mechanical skill.

Pre-ride Inspection

To ensure safety, it is your responsibility to perform a pre-ride inspection and make sure that any problem you find is corrected. A pre-ride inspection is a must, not only for safety, but because having a breakdown, or even a flat tyre, can be a major inconvenience.

Check the following items before you get on your vehicle:

- Fuel level - Fill fuel tank when necessary. ➔ P. 34
- Throttle - Check for smooth opening and full closing in all steering positions. ➔ P. 83
- Engine oil level - Add engine oil if necessary. Check for leaks. ➔ P. 59
- Drive chain - Check condition and slack, adjust and lubricate if necessary. ➔ P. 76
- Brakes - Check operation;

CBF125M III ID, VII ID

Front: check brake fluid level and pads wear. ➔ P. 63, 64

Combi brake: check brake fluid level. ➔ P. 63, 64

Rear: check shoes wear and freeplay, adjust if necessary. ➔ P. 67, 65

CBF125M IV ID, VIII ID

Front and Rear: check shoes wear and freeplay, adjust if necessary. ➔ P. 73, 69

- Lights and horn - Check that lights, indicators and horn function properly.
- Engine stop switch: Check for proper function. ➔ P. 27
- Clutch - Check operation; Adjust freeplay if necessary. ➔ P. 81
- Wheels and tyres - Check condition, air pressure and adjust if necessary. ➔ P. 49, 117

Replacing Parts

Always use Honda Genuine Parts or their equivalents to ensure reliability and safety.

WARNING

Installing non-Honda parts may make your vehicle unsafe and cause a crash in which you can be seriously hurt or killed.

Always use Honda Genuine Parts or equivalents that have been designed and approved for your vehicle.

Battery

Your vehicle has a maintenance-free type battery. You do not have to check the battery electrolyte level or add distilled water. Clean the battery terminals if they become dirty or corroded.

Do not remove the battery cap seals. There is no need to remove the cap when charging.

NOTICE

Your battery is a maintenance-free type and can be permanently damaged if the cap strip is removed.

NOTICE

An improperly disposed of battery can be harmful to the environment and human health. Always confirm local regulations for proper battery disposal instruction.

What to do in an emergency

If any of the following occur, immediately see your doctor.

- Electrolyte splashes into your eyes:
 - ▶ Wash your eyes repeatedly with cool water for at least 15 minutes. Using water under pressure can damage your eyes.
- Electrolyte splashes onto your skin:
 - ▶ Remove affected clothing and wash your skin thoroughly using water.
- Electrolyte splashes into your mouth:
 - ▶ Rinse mouth thoroughly with water, and do not swallow.

WARNING

The battery gives off explosive hydrogen gas during normal operation.

A spark or flame can cause the battery to explode with enough force to kill or seriously hurt you.

Wear protective clothing and a face shield, or have a skilled mechanic do the battery servicing.

Cleaning the Battery Terminals

1. Remove the battery. ➤ P. 53
2. If the terminals are starting to corrode and are coated with a white substance, wash with warm water and wipe clean.

3. If the terminals are heavily corroded, clean and polish the terminals with a wire brush or sandpaper. Wear safety glasses.

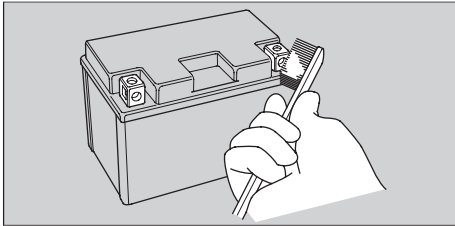

4. After cleaning, reinstall the battery.

The battery has a limited life span. Consult your dealer about when you should replace the battery. Always replace the battery with another maintenance-free battery of the same type.

NOTICE

Installing non-Honda electrical accessories can overload the electrical system, discharging the battery and possibly damaging the system.

Fuses

Fuses protect the electrical circuits on your vehicle. If something electrical on your vehicle stops working, check for and replace any blown fuses. ➔ P. 102

Inspecting and Replacing Fuses

Turn the ignition switch to the OFF position to remove and inspect fuses. If a fuse is blown, replace with a fuse of the same rating. For fuse ratings, see "Specifications." ➔ P. 118

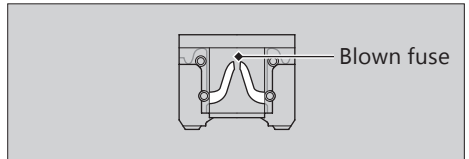

NOTICE

Replacing a fuse with one that has a higher rating greatly increases the chance of damage to the electrical system.

Maintenance Fundamentals

If a fuse fails repeatedly, you likely have an electrical fault. Have your vehicle inspected by your dealer.

Engine Oil

Engine oil consumption varies and oil quality deteriorates according to riding conditions and time elapsed.

Check the engine oil level regularly, and add the recommended engine oil if necessary. Dirty oil or old oil should be changed as soon as possible.

Selecting the Engine Oil

For recommended engine oil, see "Specifications." ➔ P. 117

If you use non-Honda engine oil, check the label to make sure that the oil satisfies all of the following standards:

- JASO T 903 standard*1: MA
- SAE standard*2: 10W-30
- API classification*3: SJ or higher

*1. The JASO T 903 standard is an index for engine oils for 4-stroke motorcycle engines. There are two classes: MA and MB. For example, the following label shows the MA classification.

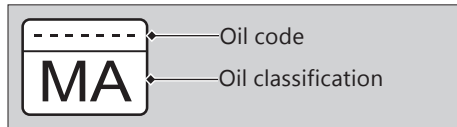

*2. The SAE standard grades oils by their viscosity.

*3. The API classification specifies the quality and performance rating of engine oils. Use SG or higher oils, excluding oils marked as "Energy Conserving" or "Resource Conserving" on the circular API service symbol.

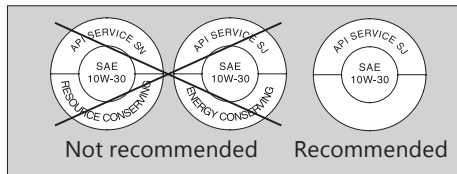

Brake Fluid

CBF125M III ID, VII ID

Do not add or replace brake fluid, except in an emergency. Use only fresh brake fluid from a sealed container. If you do add fluid, have the brake system serviced by your dealer as soon as possible.

NOTICE

Brake fluid can damage plastic and painted surfaces. Wipe up spills immediately and wash thoroughly.

Recommended brake fluid:

Honda DOT 3 or DOT 4 Brake Fluid or equivalent

Drive Chain

The drive chain must be inspected and lubricated regularly. Inspect the chain more frequently if you often ride on bad roads, ride at high speed, or ride with repeated fast acceleration. ➡ P. 76

If the chain does not move smoothly, makes strange noises, has damaged rollers, has loose pins, has missing O-rings, or kinks, have the chain inspected by your dealer.

Also inspect the drive sprocket and driven sprocket. If either has worn or damaged teeth, have the sprocket replaced by your dealer.

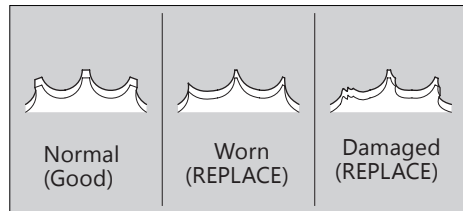

NOTICE

Use of a new chain with worn sprockets will cause rapid chain wear.

Maintenance Fundamentals

I Cleaning and Lubricating

After inspecting the slack, clean the chain and sprockets while rotating the rear wheel. Use a dry cloth with chain cleaner designed specially for O-ring chains, or neutral detergent. Use a soft brush if the chain is dirty.

After cleaning, wipe dry and lubricate with the recommended lubricant.

Recommended lubricant:

Drive chain lubricant designed specifically for O-ring chains.

If not available, use SAE 80 or 90 gear oil.

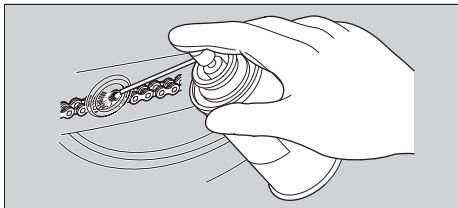

Do not use a steam cleaner, a high pressure cleaner, a wire brush, volatile solvent such as petrol and benzene, abrasive cleaner, chain cleaner or lubricant NOT designed specially for O-ring chains as these can damage the rubber O-ring seals.

Avoid getting lubricant on the brakes or tyres.

Avoid applying excess chain lubricant to prevent spray onto your clothes and the vehicle.

Crankcase Breather

Service more frequently when riding in rain, at full throttle, or after the vehicle is washed or overturned. Service if the deposit level can be seen in the transparent section of the drain tube.

If the drain tube is overflows, the air filter may become contaminated with engine oil causing poor engine performance. ➤ P. 84

Tyres (Inspecting/Replacing)

Checking the Air Pressure

Visually inspect your tyres and use an air pressure gauge to measure the air pressure at least once a month or any time you think the tyres look low. Always check air pressure when your tyres are cold.

Inspecting for Damage

Inspect the tyres for cuts, slits, or cracks that exposes fabric or cords, or nails or other foreign objects embedded in the side of the tyre or the tread. Also inspect for any unusual bumps or bulges in the side walls of the tyres.

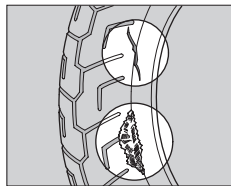

Inspecting for Abnormal Wear

Inspect the tyres for signs of abnormal wear on the contact surface.

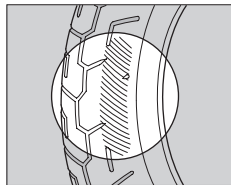

Inspecting Tread Depth

Inspect the tread wear indicators. If they become visible, replace the tyres immediately.

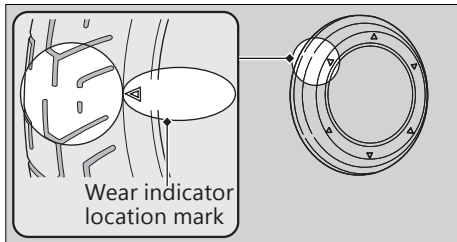

! WARNING

Riding on tyres that are excessively worn or improperly inflated can cause a crash in which you can be seriously hurt or killed.

Follow all instructions in this owner's manual regarding tyre inflation and maintenance.

Have your tyres replaced by your dealer.

For recommended tyres and air pressure, see "Specifications." ➔ P. 117

Follow these guidelines whenever you replace tyres.

- Use the recommended tyres or equivalents of the same size, construction, speed rating, and load range.

- Do not install a tube inside a tubeless tyre on this vehicle. Excessive heat build-up can cause the tube to burst.
- Use only tubeless tyres on this vehicle. The rims are designed for tubeless tyres, and during hard acceleration or braking, a tube-type tyre could slip on the rim and cause the tyre to rapidly deflate.

⚠️ WARNING

Installing improper tyres on your vehicle can adversely affect handling and stability, and can cause a crash in which you can be seriously hurt or killed.

Always use the size and type of tyres recommended in this owner's manual.

Air Cleaner

This vehicle is equipped with a viscous type air cleaner element.

Air blow cleaning or any other cleaning can degrade the viscous element performance and cause the intake of dust.

Do not perform the maintenance. Should be serviced by your dealer.

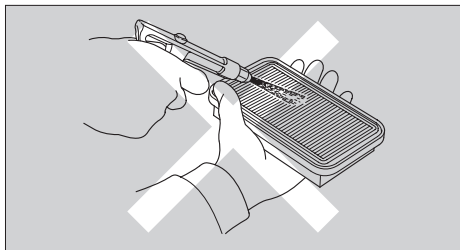

Tool

The tool kit is stored under the seat. ➔ P. 35

You can perform some roadside repairs, minor adjustments and parts replacement with the provided tools.

- 14 x 17 mm Open end wrench
- Spark plug wrench
- Standard/Philips screwdriver

Battery

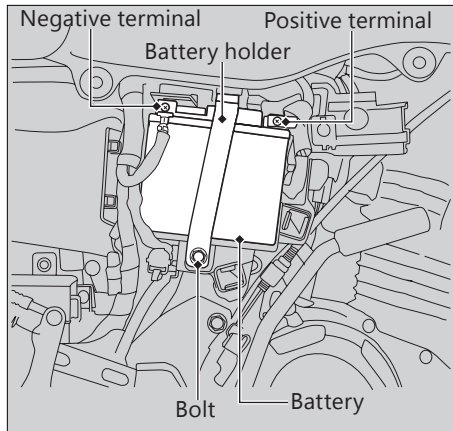

Removal

Make sure the ignition switch is in the OFF position.

1. Remove the right side cover. ➔ P. 56
2. Remove the bolt.
3. Remove the battery holder.
4. Disconnect the negative \ominus terminal from the battery.
5. Disconnect the positive \oplus terminal from the battery.
6. Remove the battery taking care not to drop the terminal nuts.

Installation

Install the parts in the reverse order of removal. Always connect the positive \oplus terminal first. Make sure that bolts and nuts are tight.

Make sure clock information is correct after the battery is reconnected. ➔ P. 24

For proper handling of the battery, see "Maintenance Fundamentals." ➔ P. 42
"Battery Goes Dead." ➔ P. 99

Drive Chain Case

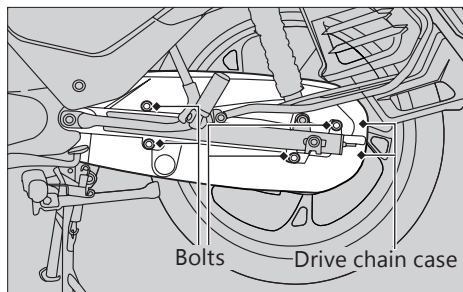

■ Removal :

1. Remove the bolts.
2. Remove the drive chain case.

■ Installation :

Install the parts in the reverse order of removal.

Torque: 10 N·m (1.0 kgf·m, 7 lbf·ft)

Seat

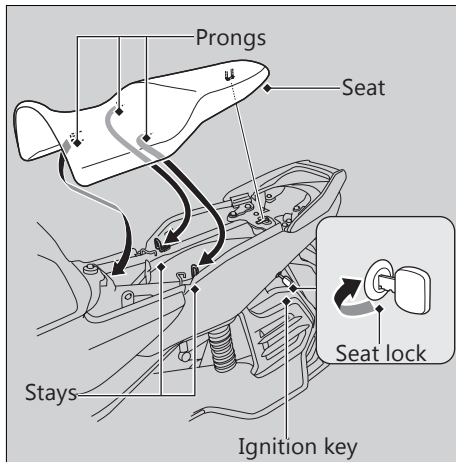

Removal

1. Insert the ignition key into the seat lock.
2. Turn it clockwise, then pull the seat up and back.

Installation:

1. Insert the prongs into the stays on the frame..
2. Push forward and down on the rear of the seat until it locks in place.

Make sure that the seat is locked securely in position to pull it up lightly.

The seat locks automatically when closed. Take care not to lock your key in the compartment under the seat.

Side Cover

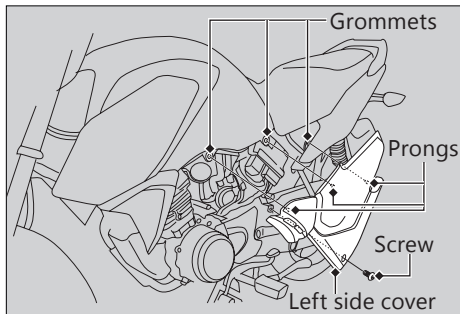

The right and left side covers can be removed in the same manner.

■ Removal :

1. Remove the screw.
2. Remove the prongs from the grommets.
3. Remove the side cover.

■ Installation :

Install the parts in the reverse order of removal.

Checking Spark Plug

For the recommended spark plug, see "Specifications". ➤ P. 117

Use only the recommended type of spark plug in the recommended heat range.

NOTICE

Using a spark plug with an improper heat range can cause engine damage.

1. Disconnect the spark plug cap from the spark plug.
2. Clean any dirt from around the spark plug base.
3. Remove the spark plug using provided spark plug wrench. ➤ P. 52

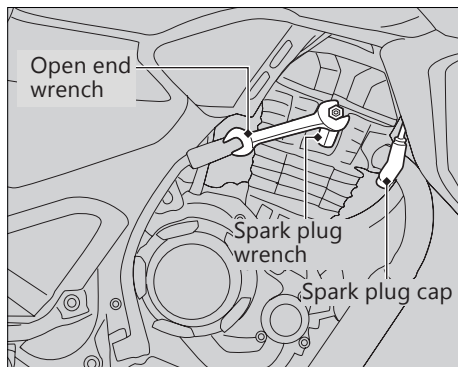

4. Inspect the electrodes and centre porcelain for deposits, erosion or carbon fouling.
 - ▶ If the erosion or deposit is heavy, replace the plug.
 - ▶ Clean a carbon or wet-fouled plug with a plug cleaner, otherwise use a wire brush.

Removing & Installing Body Components ► Checking Spark Plug

5. Check the spark plug gap using a wiretype feeler gauge.
 - If adjustment is necessary, bend the side electrode carefully.

The gap should be:

0.8 to 0.9 mm (0.03 to 0.04 in)

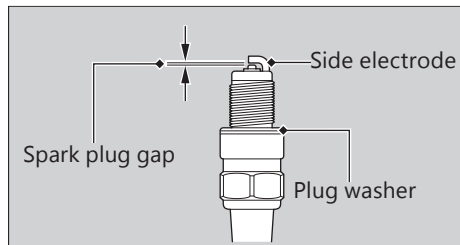

6. Make sure the plug washer is in good condition.
7. Install the spark plug. With the plug washer attached, thread the spark plug in by hand to prevent cross-threading.

8. Tighten the spark plug:
 - If the old plug is good:
 - 1/12 turn after it seats.
 - If installing a new plug, tighten it twice to prevent loosening:
 - a) First, tighten the plug:
 - NGK: 1/2 turn after it seats.
 - b) Then loosen the plug.
 - c) Next, tighten the plug again:
 - 1/8 turn after it seats.

NOTICE

An improperly tightened spark plug can damage the engine. If a plug is too loose, a piston may be damaged. If a plug is too tight, the threads may be damaged.

9. Install the parts in the reverse order of removal.
 - When reinstalling the spark plug cap, take care to avoid pinching any cables or wires.

Checking the Engine Oil

1. If the engine is cold, idle the engine for 3 to 5 minutes.
2. Turn the ignition switch to the OFF position and wait 2 to 3 minutes.
3. Place your vehicle on its centre stand on a firm, level surface.
4. Remove the oil fill cap/dipstick and wipe it clean.
5. Insert the oil fill cap/dipstick until it seats, but don't screw it in.
6. Check that the oil level is between the upper level and lower level marks on the oil fill cap/dipstick.
7. Securely install the oil fill cap/dipstick.

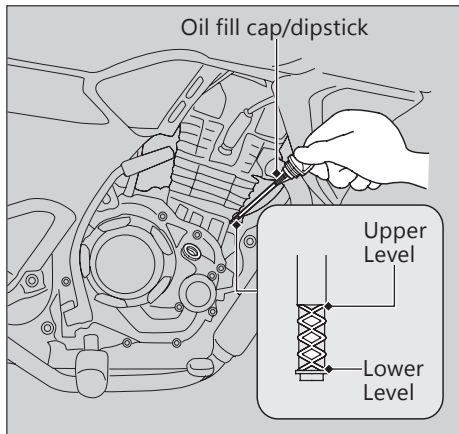

Adding Engine Oil

If the engine oil is below or near the lower level mark, add the recommended engine oil.

➔ P. 46, 117

1. Remove the oil fill cap/dipstick. Add the recommended oil until it reaches the upper level mark.
 - Place your vehicle on its centre stand on a firm, level surface when checking the oil level.
 - Do not overfill above the upper level mark.
 - Make sure no foreign objects enter the oil filler opening.
 - Wipe up any spills immediately.
2. Securely reinstall the oil fill cap/dipstick.

NOTICE

Overfilling with oil or operating with insufficient oil can cause damage to your engine. Do not mix different brands and grades of oil. This may affect lubrication and clutch operation.

For the recommended oil and oil selection guidelines, see "Maintenance Fundamentals".

➔ P. 46

Changing Engine Oil and Filter

Changing the oil and filter requires special tools. We recommend that you have your vehicle serviced by your dealer.

Use a new Honda Genuine oil filter or equivalent specified for your model.

NOTICE

Using the wrong oil filter can result in serious damage to the engine.

1. If the engine is cold, idle the engine for 3 to 5 minutes.
2. Turn the ignition switch to the OFF position and wait for 2 to 3 minutes.
3. Place your vehicle on its centre stand on a firm, level surface.
4. Place a drain pan under the drain bolt.
5. Remove the oil fill cap/dipstick, drain bolt and sealing washer to drain the oil.

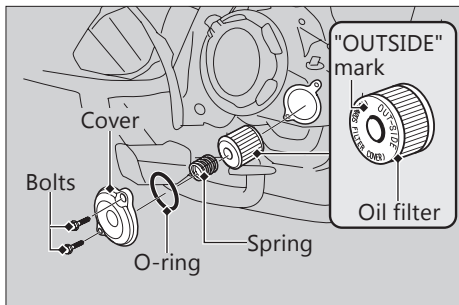
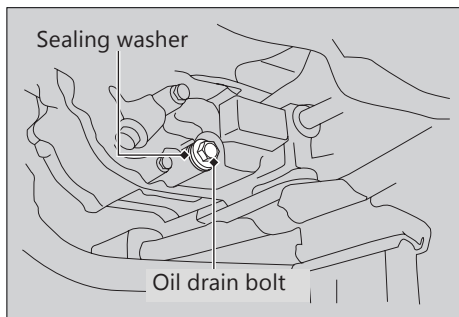

Engine Oil ► Changing Engine Oil and Filter

6. Remove the oil filter cover, oil filter, spring and gasket by removing the oil filter cover bolts and let the remaining oil drain out.
 - Discard the oil and oil filter at an approved recycling centre.
7. Install the new oil filter with the OUT-SIDE mark facing out.
8. Install the new oil filter spring into the oil filter cover and then install the new gasket and oil filter cover by tightening the oil filter cover bolts.

Torque: 10 N·m (1.0 kgf·m, 7 lbf·ft)

9. Install a new sealing washer onto the drain bolt. Tighten the drain bolt.

Torque: 24 N·m (2.5 kgf·m, 18 lbf·ft)

10. Fill the crankcase with the recommended oil (► P. 46) and install the oil fill cap/dipstick.

Required oil

When changing oil & filter:

0.9 litres (1 US qt, 0.8 Imp qt)

When changing oil only:

0.85 litres (0.9 US qt, 0.7 Imp qt)

11. Check the oil level. ► P. 59

12. Check that there are no oil leaks.

NOTICE

Improper installation of the oil filter can result in serious damage to the engine.

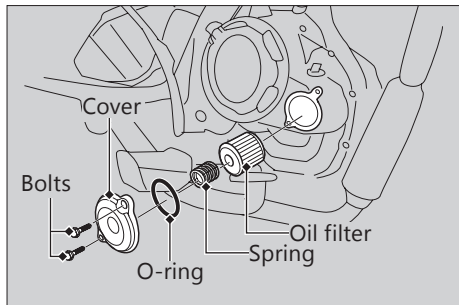

Checking Brake Fluid

CBF125M III ID, VII ID

1. Place your vehicle in an upright position on a firm, level surface.
2. **Front** Check that the brake fluid reservoir is horizontal and that the fluid level is above the LWR level mark.

Rear Check that the brake fluid reservoir is horizontal and that the fluid level is between the LOWER level and UPPER level marks.

If the brake fluid level in the reservoir is below the LWR mark or LOWER level mark or the

brake lever freeplay becomes excessive, inspect the brake pads for wear.

If the brake pads are not worn, you most likely have a leak. Have your vehicle inspected by your dealer.

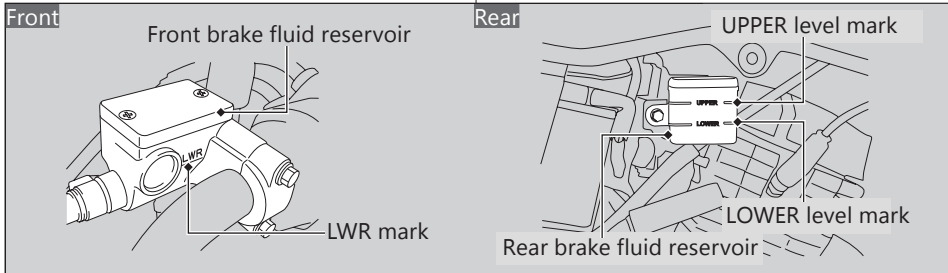

Inspecting the Front Brake Pads

CBF125M III ID, VII ID

Check the condition of the brake pad wear indicators.

The pads need to be replaced if a brake pad is worn to the bottom of the indicator.

1. Inspect the brake pads from in front of the brake caliper.

If necessary have the pads replaced by your dealer.

Always replace both left and right brake pads at the same time.

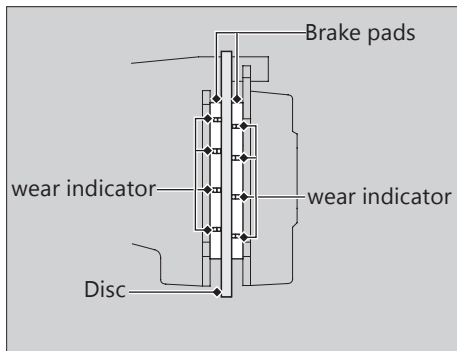

Inspecting the Rear Brake Pedal Freeplay

1. Place your vehicle on its centre stand on a firm, level surface.
2. Measure the distance the rear brake pedal moves before the brake takes hold.

Freeplay at the tip of the brake pedal: 20 to 30 mm (0.78 to 1.18 in)

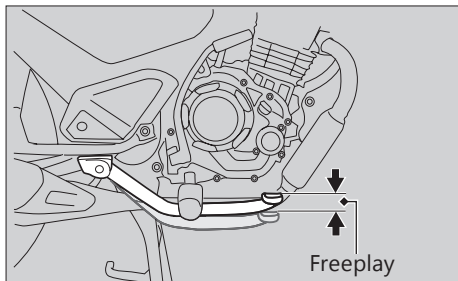

Make sure the the brake rod, brake arm, spring and fastener are in good condition.

Adjusting the Rear Brake Pedal Freeplay

CBF125M III ID, VII ID

Make sure the cut-out on the adjusting nut is seated on the brake arm pin when adjusting the freeplay.

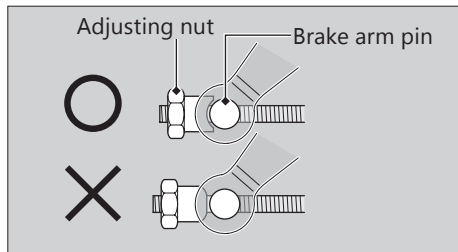

If proper adjustment cannot be obtained by this method, see your dealer.

Brakes ► Inspecting the Rear Brake Pedal Freeplay

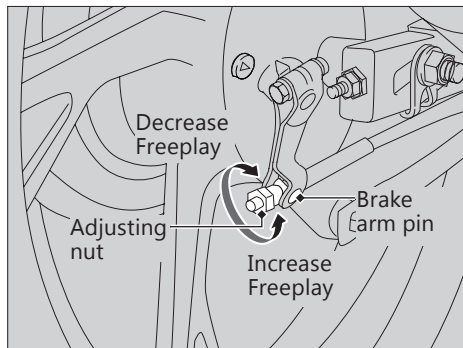

1. Adjust by turning the rear brake adjusting nut a half-turn at a time.
2. Apply the brake several times and check for free wheel rotation after the brake pedal is released.

3. Push the brake arm to confirm that there is a gap between the rear brake adjusting nut and brake arm pin.

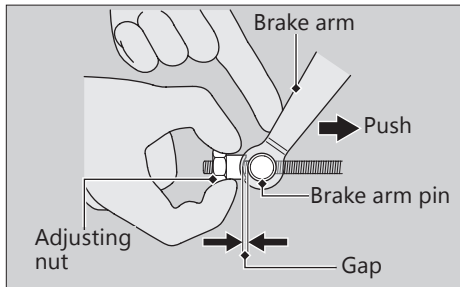

After adjustment, confirm the freeplay of the brake pedal.

Make sure the brake rod, brake arm, spring and fastener are in good condition.

NOTICE

Do not turn the adjuster beyond its natural limits.

Inspecting Rear Brake Shoe Wear

CBF125M III ID, VII ID

The rear brake is equipped with a brake wear indicator.

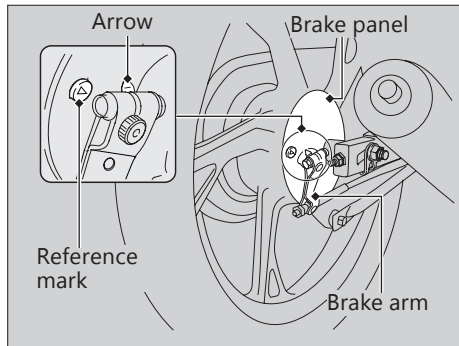

When the brake is applied, an arrow attached to the brake arm moves toward a reference mark on the brake panel. If the arrow aligns with the reference mark on full application of the brake, the brake shoes must be replaced. See your dealer for this service.

When the brake service is necessary, see your dealer. Use only Honda Genuine Parts or its equivalent.

Inspecting the Front Brake Lever Freeplay

CBF125M IV ID, VIII ID

1. Place your vehicle on its centre stand on a firm, level surface.
2. Measure the distance the front brake lever move before the brake takes hold.

Freeplay at the tip of the brake lever: 10 to 20 mm (0.39 to 0.79 in)

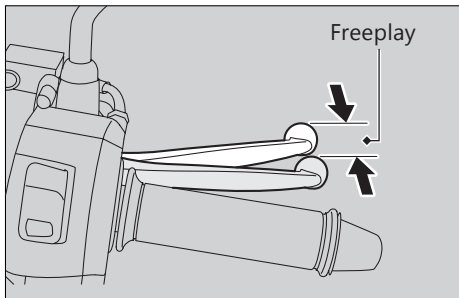

Check the brake cable for kinks or signs of wear. If necessary have it replaced by your dealer.

Lubricate the brake cable with a commercially available cable lubricant to prevent premature wear and corrosion.

Make sure the brake arm, spring and fastener are in good condition.

Adjusting the Front Brake Lever & Rear brake Pedal Freeplay

CBF125M IV ID, VIII ID

Adjust the freeplay of the front brake lever and rear brake pedal with the front wheel pointed straight ahead in the order of front brake followed by rear brake.

Make sure the cut-out on the adjusting nut is seated on the brake arm pin when adjusting the freeplay.

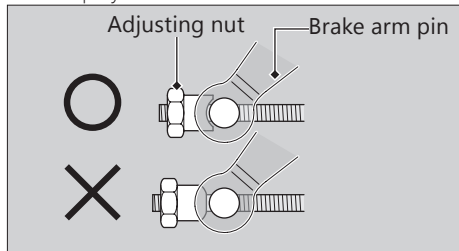

If proper adjustment cannot be obtained by this method, see your dealer.

1. Turn No.1 adjusting nut a half-turn at a time while firmly pushing the brake arm. Check the freeplay of the front brake lever after turning the adjusting nut clockwise (less freeplay) by hand until the nut no longer turns.
 - If the freeplay of the front brake lever is out of the specified range, readjust the freeplay by rotating the No.1 adjusting nut.

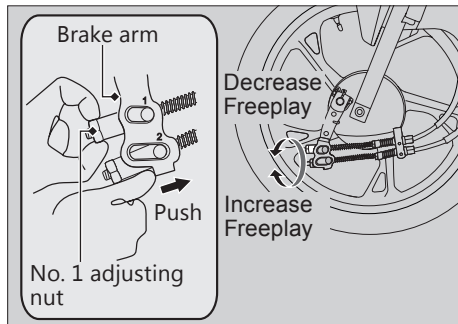

Brakes ▶ Adjusting the Front Brake Lever & Rear brake Pedal Freeplay

2. Without pushing the brake arm, adjust No. 2 adjusting nut so that the gaps between the brake arm and brake arm pin for No. 1 and No. 2 are as follows.

Gap of No.1 : no gap

Gap of No.2 : approximately 1 mm (0.04 in)

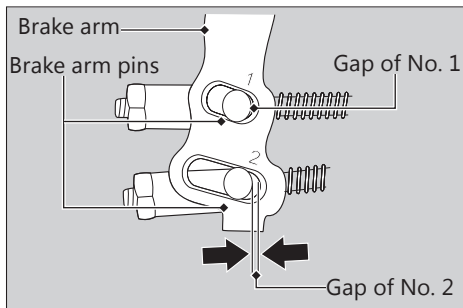

To adjust No.2 adjusting nut, turn the No.2 adjusting nut a half-turn at a time while firmly pushing the brake arm.

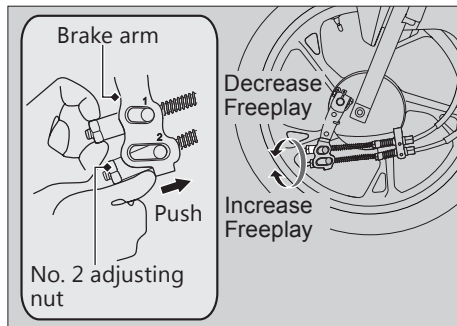

Brakes ► Adjusting the Front Brake Lever & Rear brake Pedal Freeplay

3. While pushing the front brake arm, confirm there is a gap between the brake arm and brake arm pin for No.1 and No.2.

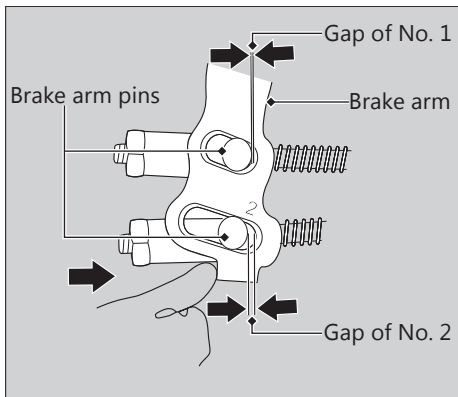

4. Apply the brakes several times and check for free wheel rotation after the brake lever and brake pedal are released.
5. Adjust the freeplay of the rear brake pedal by turning the rear brake adjusting nut a half-turn at a time.

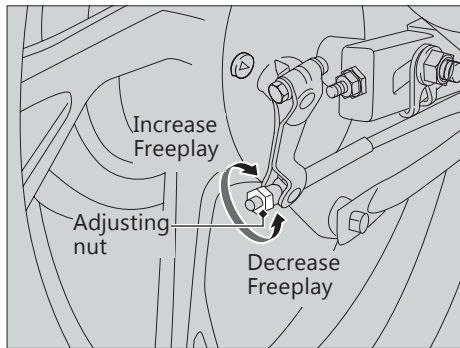

Brakes ► Adjusting the Front Brake Lever & Rear brake Pedal Freeplay

6. Push the brake arm to confirm that there is a gap between the rear brake adjusting nut and brake arm pin.

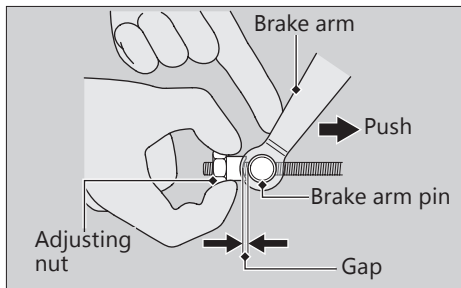

7. Apply the brake several times and check for free wheel rotation after the brake pedal is released.

After adjustment, confirm the freeplay of the brake pedal.

NOTICE

Do not turn the adjuster beyond its natural limits.

Make sure the brake rod, brake arm, spring and fastener are in good condition.

Inspecting Brake Shoe Wear

CBF125M IV ID, VIII ID

The front and rear brake are equipped with a brake wear indicator.

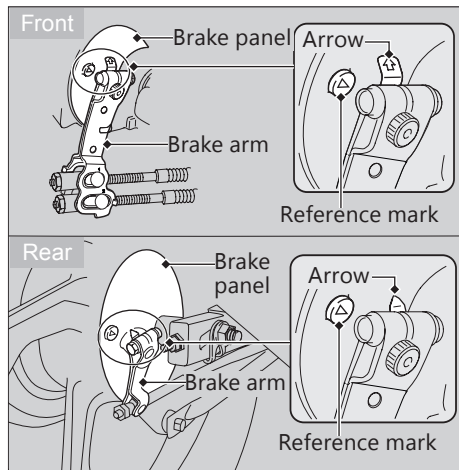

When the brake is applied, an arrow attached to the brake arm moves toward a reference mark on the brake panel. If the arrow aligns with the reference mark on full application of the brake, the brake shoes must be replaced.

See your dealer for this service.

When the brake service is necessary, see your dealer. Use only Honda Genuine Parts or its equivalent.

Adjusting the Brakelight Switch

Check the operation of the brake light switch. Hold the brakelight switch and turn the adjusting nut in the direction A if the switch operates too late, or turn the nut in the direction B if the switch operates too soon.

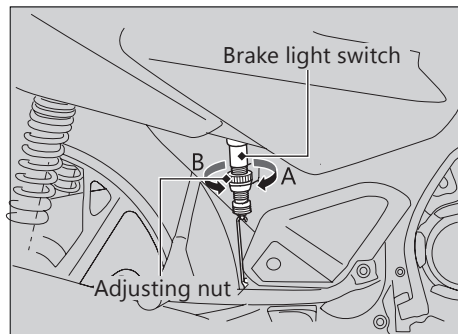

Checking the Side Stand

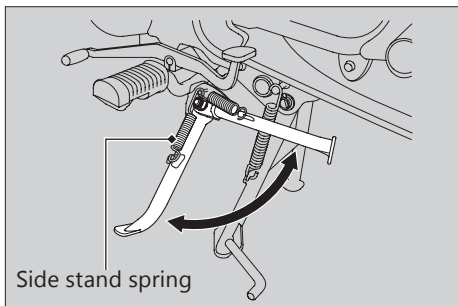

1. Check that the side stand operates smoothly. If the side stand is stiff or squeaky, clean the pivot area and lubricate the pivot bolt with clean grease.
2. Check the spring for damage or loss of tension.

Inspecting the Drive Chain Slack

Check the drive chain slack at several points along the chain. If the slack is not constant at all points, some links may be kinked and binding.

Have the chain inspected by your dealer.

1. Shift the transmission to Neutral. Stop the engine.
2. Place your vehicle on its centre stand on a level surface.

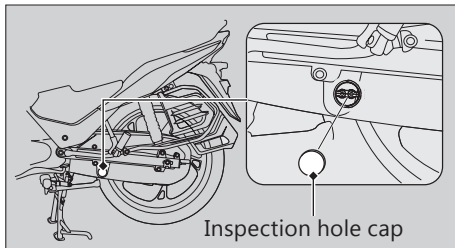

3. Remove the inspection hole cap.
4. Move your drive chain up and down with your finger.

Drive chain slack:

20 to 30 mm (0.8 to 1.2 in)

- ▶ Do not ride your vehicle if the slack exceeds 50 mm (2.0 in).

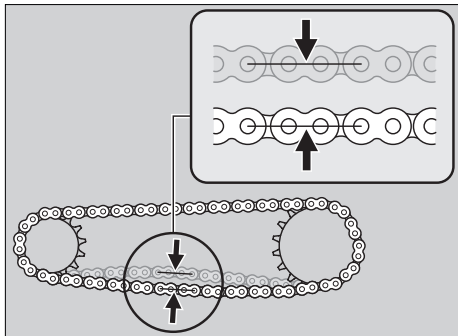

5. Rotate the rear wheel and check that the chain moves smoothly.

6. Remove the chain case. ➔ P. 54
7. Inspect the sprockets. ➔ P. 47
8. Clean and lubricate the drive chain. ➔ P. 48
9. Install the parts in the reverse order of the removal.

Adjusting the Drive Chain Slack

Adjusting the chain requires special tools. Have the drive chain slack adjusted by your dealer.

1. Shift the transmission to Neutral. Stop the engine.
2. Place your vehicle on its centre stand on a firm, level surface.
3. Loosen the rear axle nut.
4. Loosen the lock nuts on both adjusting bolts.

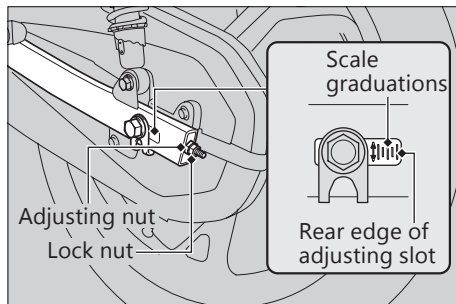
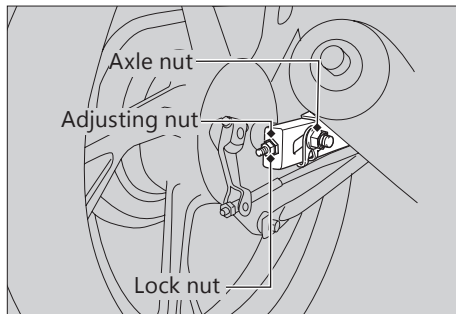

5. Turn both adjusting nuts an equal number of turns until the correct drive chain slack is obtained. Turn the adjusting nuts clockwise to tighten the chain. Turn the adjusting nuts counterclockwise and push the rear wheel toward the front to provide more slack. Adjust the slack at a point midway between the front sprocket and the rear sprocket. Check the drive chain slack. ➤ P. 76
 6. Check rear axle alignment by making sure the end of the chain adjuster aligns with the scale graduations on both sides of the swingarm. Both marks should correspond. If axle is misaligned, turn the right or left adjusting nut until the marks are aligned and recheck chain slack.
 7. Tighten the rear axle nut.
- Torque: 54 N·m (5.5 kgf·m, 40 lbf·ft)**
8. Tighten the drive chain adjusting nuts lightly, then hold the adjusting nuts and tighten the lock nuts.
 9. Recheck drive chain slack.

10. Rear brake pedal freeplay is affected when repositioning the rear wheel to adjust the drive chain slack. Check rear brake pedal freeplay and adjust as necessary. ➤ P. 65
11. Reinstall the inspection hole cap.

If a torque wrench was not used for installation, see your dealer as soon as possible to verify proper assembly.

Improper assembly may lead to loss of braking capacity.

Drive Chain ► Checking the Drive Chain Slider

Checking the Drive Chain Wear

Check the chain wear label when adjusting the drive chain. If the index mark of the adjusting plate enters the red zone on the label after the chain has been adjusted to the proper slack, the chain is excessively worn and must be replaced.

Drive chain must be replaced with new sprocket set.

Chain: DID420 ADV
LGBR420OR

If necessary have the drive chain replaced by your dealer.

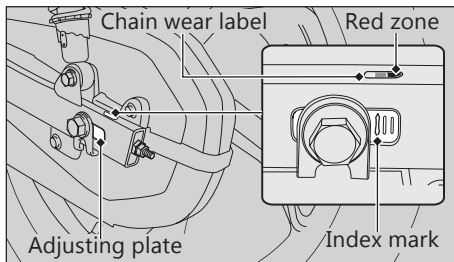

Checking the Drive Chain Slider

Check the condition of the drive chain slider.

The drive chain slider will need to be replaced if the chain slider is worn to the wear limit indicator.

If necessary have the drive chain slider replaced by your dealer.

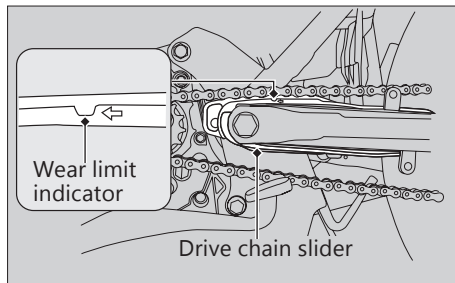

Checking the Clutch

Checking the Clutch Lever Freeplay

Check the clutch lever freeplay.

Freeplay at the clutch lever:
10 to 20 mm (0.39 to 0.79 in)

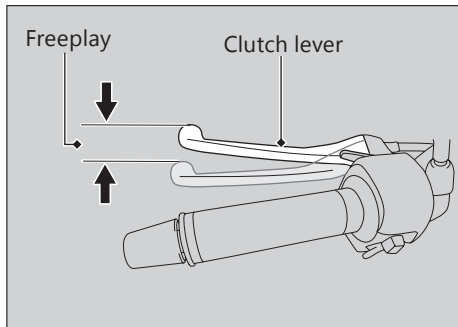

Check the clutch cable for kinks or signs of wear. If necessary have it replaced by your dealer.

Lubricate the clutch cable with a commercially available cable lubricant to prevent premature wear and corrosion.

NOTICE

Improper freeplay adjustment can cause premature clutch wear.

Adjusting the Clutch Lever Freeplay

1. Loosen the lock nut.
2. Turn the adjusting nut until the clutch lever freeplay is 10 to 20 mm (0.4 to 0.8 in).
3. Tighten the locknut and check the clutch lever freeplay.
4. Start the engine, pull the clutch lever in and shift into gear. Make sure the engine does not stall and the vehicle does not creep. Gradually release the clutch lever and open the throttle. Your vehicle should move smoothly and accelerrate gradually.

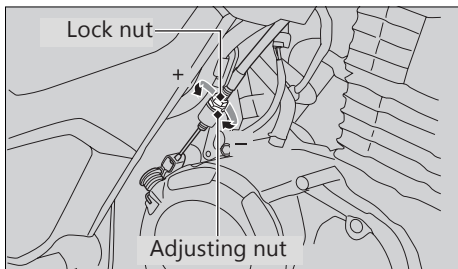

If proper adjustment cannot be obtained or the clutch does not work correctly, see your dealer.

Checking the Throttle

With the engine off, check that the throttle rotates smoothly from fully closed to fully open in all steering positions and throttle freeplay is correct. If the throttle does not move smoothly, close automatically, or if the cable is damaged, have the vehicle inspected by your dealer.

Freeplay at the throttle grip flange:

2 to 6 mm (0.1 to 0.2 in).

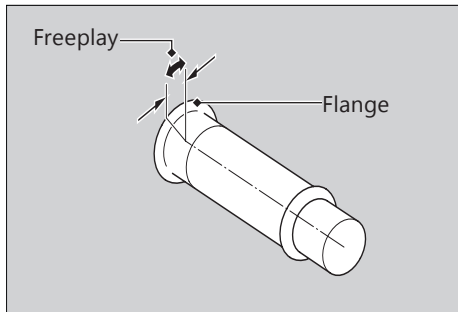

Cleaning the Crankcase Breather

1. Remove the left side cover. ➤ P. 56
2. Place a suitable container to receive deposits.
3. Remove the crankcase breather tube and drain deposits.
4. Reinstall the crankcase breather tube.

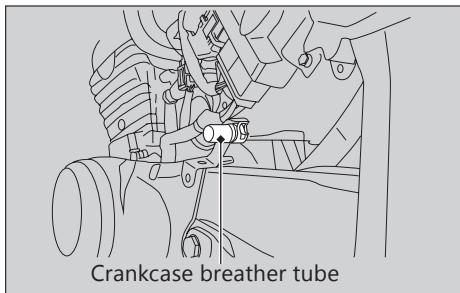

Adjusting the Headlight Aim

You can adjust vertical aim of the headlight for proper alignment. To move the headlight, loosen the bolt.

Tighten the bolt after adjustment.
Obey local laws and regulations.

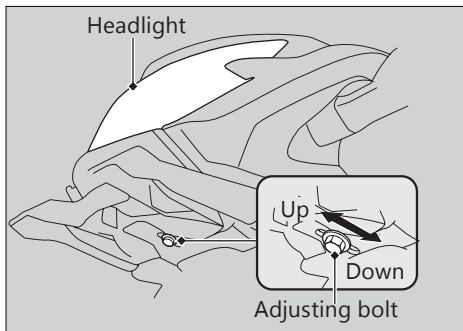

Other Adjustments ► Adjusting the Rear Suspension

Adjusting the Rear Suspension

Adjusting the suspension requires a pin spanner. We recommend that you have your vehicle serviced by your dealer.

I Spring Preload

You can adjust the spring preload by the adjuster to suit the load or the road surface. Use the pin spanner to turn the adjuster. Position 1 is for a decrease spring preload (soft), or turn the position 3 to 5 to increase spring preload (hard). The standard position is 2.

NOTICE

Attempting to adjust directly from 1 to 5 or 5 to 1 may damage the shock absorber.

NOTICE

Do not turn the adjuster beyond its limits. Adjust both left and right shock absorbers to the same spring preload.

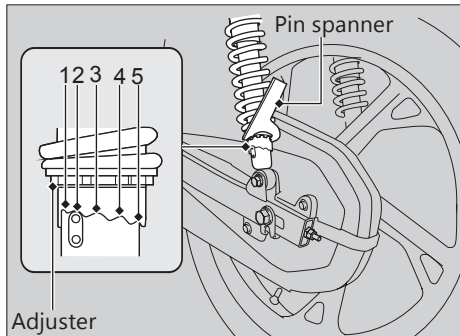

Troubleshooting

| | | | |
|--|--------|--|--------|
| Engine Will Not Start | P. 88 | Unstable Engine Operation Occur | |
| Warning Indicators On | P. 89 | Intermittently | P. 103 |
| PGM-FI (Programmed Fuel Injection) | | | |
| Malfunction Indicator Lamp (MIL)..... | P. 89 | | |
| Other Warning Indications | P. 90 | | |
| Fuel Gauge Failure Indication..... | P. 90 | | |
| Tyre Puncture | P. 91 | | |
| Electrical Trouble | P. 99 | | |
| Battery Goes Dead..... | P. 99 | | |
| Burned-out Light Bulb..... | P. 99 | | |
| Blown Fuse..... | P. 102 | | |

Starter Motor Operates But Engine Does Not Start

Check the following items:

- Check the correct engine starting sequence. ➤P. 30
- Check that there is petrol in the fuel tank.
- Check if the PGM-FI malfunction indicator lamp (MIL) is on.
 - ▶ If the indicator lamp is on, contact your dealer as soon as possible.

Starter Motor Does Not Operate

Check the following items:

- Check the correct engine starting sequence. ➤P. 30
- Make sure engine stop switch is in the  (Run) position. ➤P. 27
- Check for a blown fuse. ➤P. 102
- Check for a loose battery connection (➤P. 53) or battery terminal corrosion (➤P. 43).
- Check the condition of the battery. ➤P. 43

If the problem continues, have your vehicle inspected by your dealer.

PGM-FI (Programmed Fuel Injection) Malfunction Indicator Lamp (MIL)

If the indicator comes on while riding, you may have a serious problem with the PGM-FI system. Reduce speed and have your vehicle inspected by your dealer as soon as possible.

Other Warning Indications

Fuel Gauge Failure Indication

If the fuel system has an error, the fuel gauge indicators will be displayed as shown in the illustration.

If this occurs, see your dealer as soon as possible.

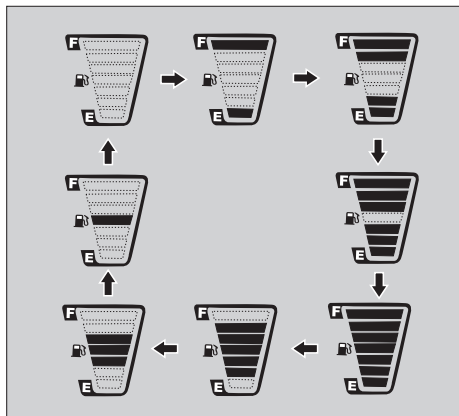
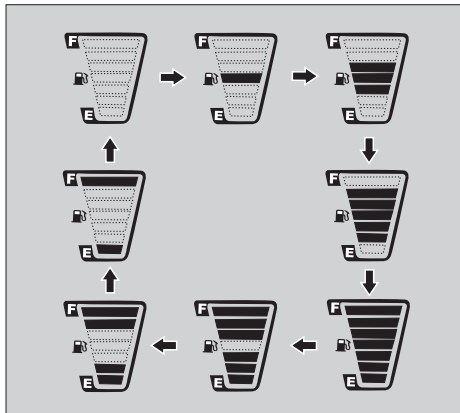

Tyre Puncture

Repairing a puncture or removing a wheel requires special tools and technical expertise. We recommend you have this type of service performed by your dealer.

After an emergency repair, always have the tyre inspected/replaced by your dealer.

Emergency Repair Using a Tyre Repair Kit

If your tyre has a minor puncture, you can make an emergency repair using a tubeless tyre repair kit.

Follow the instructions provided with the emergency tyre repair kit.

Riding your vehicle with a temporary tyre repair is very risky. Do not exceed 50 km/h (30 mph). Have the tyre replaced by your dealer as soon as possible.

WARNING

Riding your vehicle with a temporary tyre repair can be risky. If the temporary repair fails, you can crash and be seriously injured or killed.

If you must ride with a temporary tyre repair, ride slowly and carefully and do not exceed 50 km/h (30 mph) until the tyre is replaced.

Removing Wheels

Follow these procedures if you need to remove a wheel in order to repair a puncture.

Front Wheel

CBF125M II ID, VII ID

Removal

1. Place your vehicle on its centre stand on a firm, level surface.
2. Support your vehicle securely and raise the front wheel off the ground using a maintenance stand or a hoist.
3. Loosen the front axle nut.
4. Remove the front axle shaft, front wheel and side collars.
 - Avoid getting grease, oil, or dirt on the disc or pad surfaces.
 - Do not pull the brake lever while the front wheel is removed.

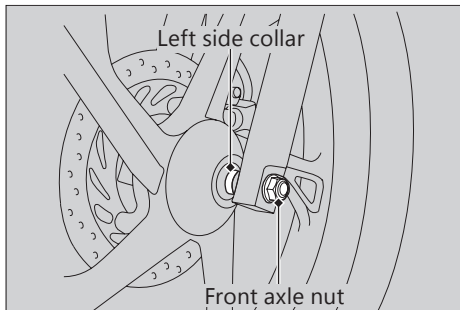
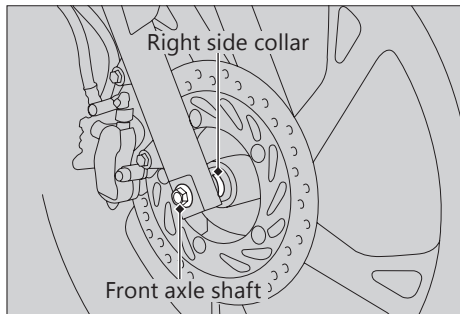

Installation

1. Attach the side collars.
2. Position the wheel between the fork legs and insert the front axle shaft from the right side, through the right fork leg and wheel hub.

NOTICE

When installing a wheel or caliper into original position, carefully fit the brake disc between the pads to avoid scratching them.

3. Install and tighten the front axle nut.

Torque: 54 N·m (5.5 kgf·m, 40 lbf·ft)

4. After installing the wheel, apply the brake lever several times, then check if the wheel rotates freely. Recheck the wheel if the brake drags or if the wheel does not rotate freely.

If a torque wrench was not used for installation, see your dealer as soon as possible to verify proper assembly. Improper assembly may lead to loss of braking capacity.

Front Wheel

CBF125M IV ID, VIII ID

Removal

1. Place your vehicle on its centre stand on a firm, level surface.
2. Raise the front wheel off the ground by placing a support block under the engine.

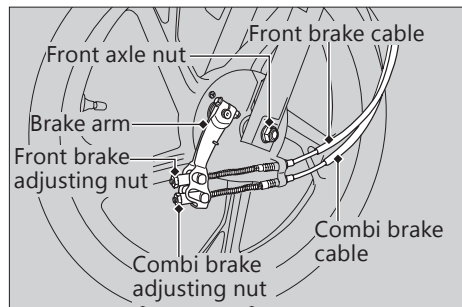

3. Remove the front brake adjusting nut and combi brake adjusting nut.
4. Remove the front and combi brake cable from the brake arm.

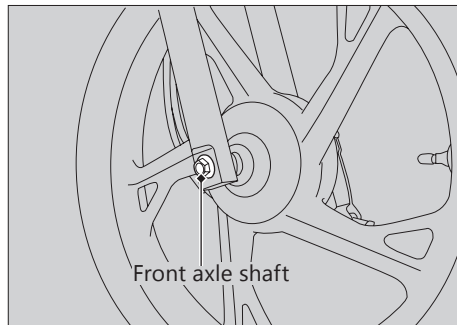

5. Remove the front axle nut.
6. Remove the front axle shaft and the wheel.

Installation

1. Install the side collar into right side wheel hub.
2. Position the wheel between the fork legs and insert the front axle shaft from the right side, through the right fork leg and wheel hub.

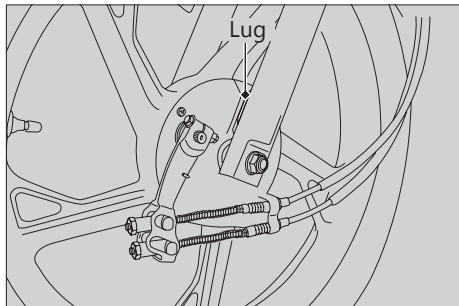

3. Make sure that the lug on the left fork leg is located in the brake panel.

4. Tighten front the axle nut.

Torque: 54 N·m (5.5 kgf·m, 40 lbf·ft)

5. Adjust the front brake. ► P. 69
6. After installing the wheel, apply the brake several times and then check if the wheel rotates freely. Recheck the wheel if the brake drags or if the wheel does not rotate freely.

If a torque wrench was not used for installation, see your dealer as soon as possible to verify proper assembly. Improper assembly may lead to loss of braking capacity.

Rear Wheel

Removal

1. Support your vehicle securely and raise the rear wheel off the ground using the centre stand or a hoist.
2. Remove the rear brake adjusting nut, disconnect the brake rod from the brake arm by pushing down on the rear brake pedal.
3. Disconnect the brake stopper arm from the brake panel by removing the cotter pin, stopper arm nut, washer and rubber grommet.
4. Remove the drive chain case. **►**P. 54
5. Loosen the drive chain lock nuts and drive chain adjuster nuts on both sides of the swingarm.
6. Remove the rear axle nut while holding the rear axle shaft at the other end with a wrench.

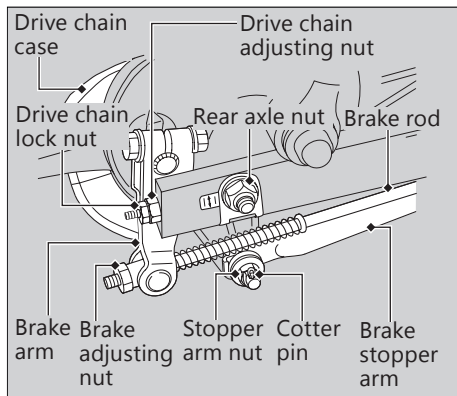

7. Remove the drive chain from the driven sprocket by pushing the rear wheel forward.
8. Remove the rear axle shaft, rear wheel and side collars from the swingarm.

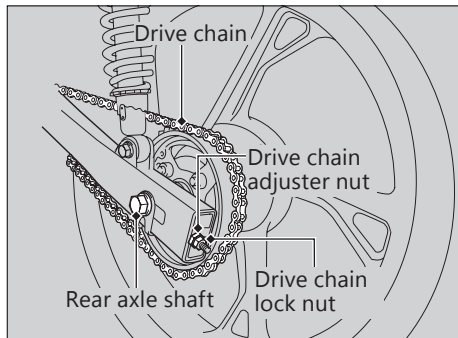

Installation

1. Install the side collars into rear wheel.
2. Place the rear wheel between the swingarm and install the drive chain over the driven sprocket.
3. Insert the rear axle shaft from the left side, through the left swingarm, wheel hub and brake panel.

4. Temporarily tighten the rear axle nut.
5. Reassemble the brake stopper arm and tighten the stopper arm nut.

Torque: 22 N·m (2.2 kgf·m, 16 lbf·ft)

6. Connect the brake rod to the brake arm.
7. Adjust the drive chain. ►P. 78
8. Adjust the rear brake freeplay. ►P. 65
9. Tighten the rear axle nut.

Torque: 54 N·m (5.5 kgf·m, 40 lbf·ft)

10. Reassemble the drive chain case. ►P. 56
11. After installing the wheel, apply the brake pedal several times, then check if the wheel rotates freely. Recheck the wheel if the brake drags or if the wheel does not rotate freely.

If a torque wrench was not used for installation, see your dealer as soon as possible to verify proper assembly.

Tyre Puncture ► Removing Wheels

Improper assembly may lead to loss of braking capacity.

A used cotter pin may not effectively secure a fastener. Always replace a used cotter pin with a new one.

Battery Goes Dead

Charge the battery using a motorcycle battery charger.

Remove the battery from the vehicle before charging.

Do not use an automobile-type battery charger, as these can overheat a motorcycle battery and cause permanent damage.

If the battery does not recover after recharging, contact your dealer.

NOTICE

Jump starting using an automobile battery can damage your vehicle's electrical system and is not recommended.

Burned-out Light Bulb

Follow the procedure below to replace a burned-out light bulb.

Turn the ignition switch to the OFF or LOCK position.

Allow the bulb to cool before replacing it.

Do not use bulbs other than those specified.

Check the replacement bulb for correct operation before riding.

For the light bulb wattage, see "Specifications." ▣ P. 118

| Headlight

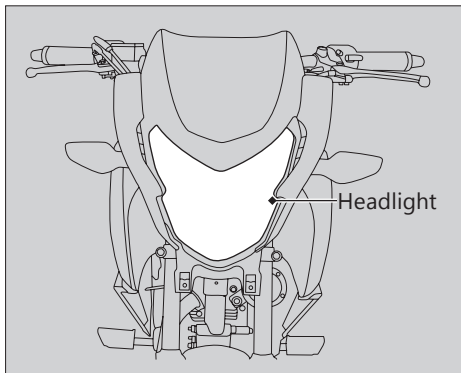

The headlight uses several LEDs.
If there is an LED which is not turned on, see your dealer for servicing.

| Brake/taillight Bulb

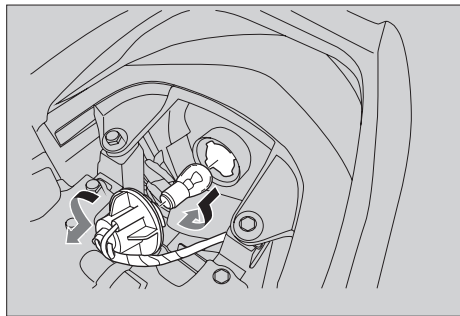

1. Remove the seat. ► P. 54
2. Turn the socket counterclockwise, and remove it.
3. Slightly press the bulb and turn it counterclockwise.
4. Install a new bulb and parts in reverse order of removal.

Front/Rear Turn Signal Light Bulb

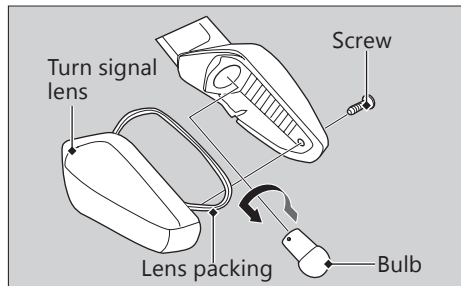

1. Remove the screw.
2. Remove the turn signal lens and lens packing.
3. Slightly press the bulb and turn it counterclockwise.
4. Install a new bulb and parts in the reverse order of removal.
 - Use only the amber bulb.

Torque: 2.5 N·m (0.2 kgf·m, 1.8 lbf·ft)

License Plate Light Bulb

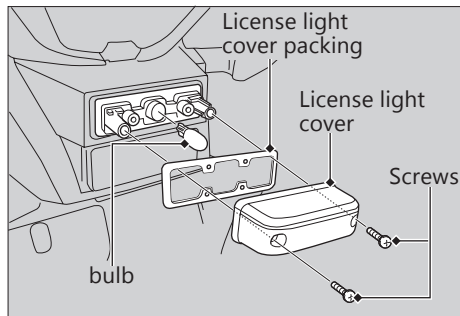

1. Remove the screws, license light cover and license light cover packing.
2. Pull out the bulb without turning it.
3. Install a new bulb and parts in reverse order of removal.
4. Install and tighten the screws.

Torque: 1 N·m (0.1 kgf·m, 0.7 lbf·ft)

Blown Fuse

Before handling fuses, see “Inspecting and Replacing Fuses.” ► P. 45

| Main Fuse & FI Fuse

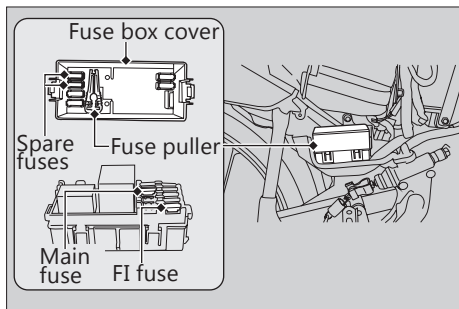

1. Remove the right side cover. ► P. 56
2. Open the fuse box cover.
3. Pull the fuses out one by one with the fuse puller and check for a blown fuse. Always replace a blown fuse with a spare fuse of the same rating.
► Spare fuses are provided in the fuse box cover.
4. Reinstall parts in the reverse order of removal.

NOTICE

If a fuse fails repeatedly, you likely have an electrical problem. Have your vehicle inspected by your dealer.

Unstable Engine Operation Occurs Intermittently

If the fuel pump filter is clogged, unstable engine operation will occur intermittently while riding.

Even if this symptom occurs, you can continue to ride your vehicle.

If unstable engine operation occurs even if sufficient fuel is available, have your vehicle inspected by your dealer as soon as possible.

Information

| | |
|--|--------|
| Keys | P. 105 |
| Instruments, Controls, & Other Features | P. 106 |
| Caring for Your Vehicle | P. 107 |
| Storing Your Vehicle | P. 110 |
| Transporting Your Vehicle | P. 111 |
| You & the Environment | P. 112 |
| Serial Numbers | P. 113 |
| Fuels Containing Alcohol | P. 114 |
| Catalytic Converters | P. 115 |

Keys

Ignition key

Be sure to record the key number provided with the key number plate. Store the spare key and key number in a safe location.

To make a duplicate, take the spare key or the key number to your dealer.

If you lose all ignition keys and the key number, the ignition switch assembly will probably have to be removed by your dealer to determine the key number.

A metal key holder may cause damage to the area surrounding the ignition switch.

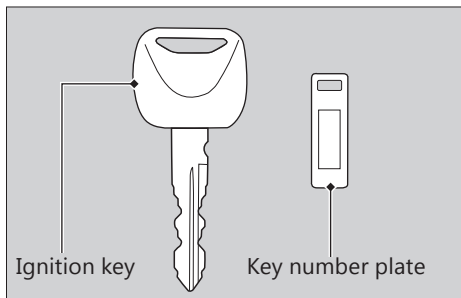

Instruments, Controls, & Other Features

Ignition Switch

Leaving the ignition switch in the ON position with the engine stopped will drain the battery. Do not turn the key while riding.

Engine Stop Switch

Do not use the engine stop switch except in an emergency. Doing so when riding will cause the engine to suddenly turn off, making riding unsafe.

If you stop the engine using the engine stop switch, turn the ignition switch to the OFF position. Failing to do so will drain the battery.

Odometer

The display locks at 999,999 when the read-out exceeds 999,999.

Tripmeter

The tripmeter returns to 0.0 when each read-out exceeds 9,999.9.

Also for tripmeter A, average fuel mileage & available driving distance are reset at the same time

Document Bag

The owner's manual, registration, and insurance information can be stored in the plastic document bag located under the seat.

Ignition Cut-off System

A banking (lean angle) sensor automatically stops the engine and fuel pump if the vehicle falls over. To reset the sensor, you must turn the ignition switch to the OFF position and back to the ON position before the engine can be restarted.

Caring for Your Vehicle

Frequent cleaning and polishing is important to ensure the life of your Honda. A clean vehicle makes it easier to spot potential problems. In particular, seawater and salts used to prevent ice on roads promote the formation of corrosion. Always wash your vehicle thoroughly after riding on coastal or treated roads.

Washing

Allow the engine, muffler, brakes, and other high-temperature parts to cool before washing.

1. Rinse your vehicle thoroughly using a low pressure garden hose to remove loose dirt.
2. If necessary, use a sponge or a soft towel with mild cleaner to remove road grime.
 - ▶ Clean the headlight lens, panels, and other plastic components with extra care to avoid scratching them. Avoid directing water into the air cleaner, muffler, and electrical parts.
3. Thoroughly rinse your vehicle with plenty of clean water and dry with a soft, clean cloth.
4. After the vehicle dries, lubricate any moving parts.
 - ▶ Make sure that no lubricant spills onto the brakes or tyres. Brake discs, pads, drum or shoes contaminated with oil will suffer greatly reduced braking effectiveness and can lead to a crash.
5. Lubricate the drive chain immediately after washing and drying the vehicle.
6. Apply a coat of wax to prevent corrosion.
 - ▶ Avoid products that contain harsh detergents or chemical solvents. These can damage the metal, paint, and plastic on your vehicle. Keep the wax clear of the tyres and brakes.
 - ▶ If your vehicle has any matte painted parts, do not apply a coat of wax to the matte painted surface.

Washing Precautions

Follow these guidelines when washing:

- Do not use high-pressure washers:
 - ▶ High-pressure water cleaners can damage moving parts and electrical parts, rendering them inoperable.
 - ▶ Water in the air intake can be drawn into the throttle body and/or enter the air cleaner.
 - Do not direct water at the muffler:
 - ▶ Water in the muffler can prevent starting and causes rust in the muffler.
 - Dry the brakes:
 - ▶ Water adversely affects braking effectiveness. After washing, apply the brakes intermittently at low speed to help dry them.
 - Do not direct water under the seat:
 - ▶ Water under the seat can damage your documents and other belongings.
-
- Do not direct water at the air cleaner:
 - ▶ Water in the air cleaner can prevent the engine from starting.
 - Do not direct water near the headlight:
 - ▶ The headlight's inside lens may fog temporarily after washing or while riding in rain. This does not impact the headlight function.
However, if you see a large amount of water or ice accumulated inside the lens(es), have your vehicle inspected by your dealer.
 - Do not use wax or polishing compounds on matte painted surface:
 - ▶ Use a soft cloth or sponge, plenty of water, and a mild detergent to clean matte painted surfaces. Dry with a soft clean cloth.

Aluminium Components

Aluminium will corrode from contact with dirt, mud, or road salt. Clean aluminium parts regularly and follow these guidelines to avoid scratches:

- Do not use stiff brushes, steel wool, or cleaners containing abrasives.
- Avoid riding over or scraping against curbs.

Panels

Follow these guidelines to prevent scratches and blemishes:

- Wash gently using a soft sponge and plenty of water.
- To remove stubborn stains, use diluted detergent and rinse thoroughly with plenty of water.
- **CBF125M III ID, VII ID**
Avoid getting petrol, brake fluid, or detergents on the instruments, panels or headlight.

- **CBF125M IV ID, VIII ID**

Avoid getting petrol or detergents on the instruments, panels or headlight.

Exhaust Pipe and Muffler

When the exhaust pipe and muffler are painted, do not use a commercially available abrasive kitchen cleaning compound. Use a neutral detergent to clean the painted surface on the exhaust pipe and muffler. If you are not sure if your exhaust pipe and muffler are painted, contact your dealer.

Storing Your Vehicle

If you store your vehicle outdoors, you should consider using a full-body vehicle cover.

If you won't be riding for an extended period, follow these guidelines:

- Wash your vehicle and wax all painted surfaces (except matte painted surfaces). Coat chrome pieces with rust-inhibiting oil.
- Lubricate the drive chain. ➤ P. 48
- Place your vehicle on its centre stand and position a block so that both tyres are off the ground.
- After rain, remove the body cover and allow the vehicle to dry.
- Remove the battery (➤ P. 53) to prevent discharge. Fully charge the battery and then place it in a shaded, well-ventilated area.
 - ▶ If you leave the battery in place, disconnect the negative \ominus terminal to prevent discharge.

After removing your vehicle from storage, inspect all maintenance items required by the Maintenance Schedule.

Transporting Your Vehicle

If your vehicle needs to be transported, it should be carried on a motorcycle trailer or a flatbed truck or trailer that has a loading ramp or lifting platform, and motorcycle tie-down straps. Never try to tow your vehicle with a wheel or wheels on the ground.

NOTICE

Towing your vehicle can cause serious damage to the transmission.

You & the Environment

Owning and riding a vehicle can be enjoyable, but you must do your part to protect the environment.

Choose Sensible Cleaners

Use a biodegradable detergent when you wash your vehicle. Avoid aerosol spray cleaners that contain chlorofluorocarbons (CFCs) which damage the atmosphere's protective ozone layer.

Recycle Wastes

Put oil and other toxic wastes in approved containers and take them to a recycling centre. Call your local or state office of public works or environmental services to find a recycling centre in your area, and to get instructions on how to dispose of non-recyclable wastes. Do not place used engine oil in the trash, or pour it

down a drain or on the ground. Used oil, petrol, and cleaning solvents contain poisons that can hurt refuse workers and contaminate drinking water, lakes, rivers, and oceans.

Serial Numbers

The frame and engine serial numbers uniquely identify your vehicle and are required in order to register your vehicle. They may also be required when ordering replacement parts. You should record these numbers and keep them in a safe place.

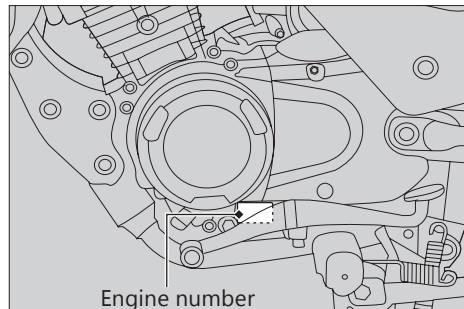
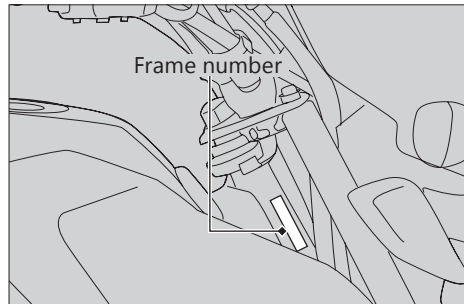

Fuels Containing Alcohol

Some conventional fuels blended with alcohol are available in some locales to help reduce emissions to meet clean air standards. If you plan to use blended fuel, check that it is unleaded and meets the minimum octane rating requirement.

The following fuel blends can be used in your vehicle:

- Ethanol (ethyl alcohol) up to 10% by volume.
 - ▶ Petrol containing ethanol may be marketed under the name Gasohol.

The use of petrol containing more than 10% ethanol may:

- Damage the painting of the fuel tank.
- Damage the rubber tubes of the fuel line.
- Cause corrosion of the fuel tank.
- Cause poor drivability.

NOTICE

Use of blended fuels containing higher than approved percentages can damage metal, rubber, plastic parts of your fuel system.

If you notice any undesirable operating symptoms or performance problems, try a different brand of petrol.

Catalytic Converters

This vehicle is equipped with a three-way catalytic converter. The catalytic converter contains precious metals that serve as catalysts in high temperature chemical reactions that convert hydrocarbons (HC), carbon monoxide (CO), and oxides of nitrogen (NOx) in the exhaust gasses into safe compounds.

A defective catalytic converter contributes to air pollution and can impair your engine's performance. A replacement unit must be an original Honda part or equivalent.

Follow these guidelines to protect your vehicle's catalytic converter.

- Always use unleaded petrol. Leaded petrol will damage the catalytic converter.
- Keep the engine in good running condition.
- Have your vehicle serviced if your engine is misfiring, backfiring, stalling, or otherwise not running properly, stop riding and turn off the engine.

Specifications

■ Main Components

| | | |
|---------------------------|------------------------|-----------------|
| Overall length | 2020 mm (79.5 in) | |
| Overall width | 785 mm (30.9 in) | |
| Overall height | 1103 mm (43.4 in) | |
| Wheelbase | 1285 mm (50.5 in) | |
| Minimum ground clearance | 160 mm (6.2 in) | |
| Caster angle | 26° | |
| Trail | 92 mm (3.6 in) | |
| Curb weight | CBF125M IV ID, VIII ID | 117 kg (258 lb) |
| | CBF125M III ID, VII ID | 118 kg (260 lb) |
| Maximum weight capacity*1 | 170 kg (375 lb) | |
| Passenger capacity | Rider and 1 passenger | |
| Minimum turning radius | 2.04 m (6.43 ft) | |

*1 Including rider, passenger, all luggage, and accessories

| | | |
|-------------------------|--|-------|
| Displacement | 123.94 cm ³ (7.563 cu-in) | |
| Bore x stroke | 50.000 x 63.121 mm (1.9684× 2.4850 in) | |
| Compression ratio | 10.0:1 | |
| Fuel | Unleaded petrol Recommended: 90 RON or higher | |
| Fuel containing alcohol | ETHANOL up to 10% by volume | |
| Tank capacity | 11 litres (2.90 US gal, 2.41 Imp gal) | |
| Battery | YTZ6V 12 V-5 Ah (10 HR) | |
| | 1st | 3.454 |
| | 2nd | 1.933 |
| | 3rd | 1.315 |
| | 4th | 1.095 |
| Gear ratio | 5th | 0.933 |
| | Reduction ratio (primary / final) | |
| | 3.421/2.928 | |

■ Service Data

| | | |
|------------------------|--|---|
| Tyre size | Front | 80/100-18M/C 47P |
| | Rear | 80/100-18M/C 54P |
| Tyre type | Tubeless | |
| Tyre air pressure | Front | (Driver only) 175 kPa (1.75 kgf/cm ² , 25 psi) (Driver and passenger) 175 kPa (1.75 kgf/cm ² , 25 psi) |
| | Rear | (Driver only) 225 kPa (2.25 kgf/cm ² , 33 psi) (Driver and passenger) 280 kPa (2.80 kgf/cm ² , 41 psi) |
| Spark plug | CPR8EA-9 (NGK) | |
| Spark plug gap | 0.8 to 0.9 mm (0.03 to 0.04 in) | |
| Idle speed | 1500 ± 100 rpm | |
| Recommended engine oil | Honda 4-stroke motorcycle oil API Service Classification SJ or higher, excluding oils marked as "Energy Conserving," or "Resource Conserving" SAE 5W-30 or 10W-30, JASO T 903 standard MA or MB (10W-30 only) | |

| | | |
|-----------------------------------|---|--|
| Engine oil capacity | After draining | 0.85 litres (0.9 US qt, 0.7 Imp qt) |
| | After draining with oil filter | 0.9 litres (1 US qt, 0.8 Imp qt) |
| | After disassembly | 1.0 litres (1.0 US qt, 0.9 Imp qt) |
| Recommended brake fluid | CBF125M III ID, VII ID | Honda Dot 3 or Dot 4 Brake fluid |
| Recommended drive chain lubricant | Drive chain lubricant If not available, use SAE 80 or 90 gear oil. | |
| Drive chain slack | 20 to 30 mm (0.8 to 1.2 in) | |
| Standard drive chain | DID420ADV or LGBR420OR | |
| | No. of links | 118 |
| standard sprocket size | Drive sprocket | 14T |
| | Driven sprocket | 41T |

Specifications

■ Bulbs

| | |
|----------------------|----------------|
| Headlight | LED |
| Position light | LED |
| Brakelight/Taillight | 12 V-21 / 5 W |
| Front turn signal | 12 V- 10 W x 2 |
| Rear turn signal | 12 V- 10 W x 2 |
| License plate light | 12 V- 5 W |

■ Fuses

| | |
|-------------|-----------|
| Main fuse | 20 A x 1 |
| Other fuses | 7.5 A x 6 |

■ Torque Specifications

| | |
|------------------------------|---------------------------------|
| Drive chain case | 10 N-m (1.0 kgf-m, 7 lbf-ft) |
| Engine oil filter cover bolt | 10 N-m (1.0 kgf-m, 7 lbf-ft) |
| Engine oil drain bolt | 24 N-m (2.4 kgf-m, 18 lbf-ft) |
| Rear axle nut | 54 N-m (5.5 kgf-m, 40 lbf-ft) |
| Front axle nut | 54 N-m (5.5 kgf-m, 40 lbf-ft) |
| Front/Rear turn signal screw | 2.5 N-m (0.2 kgf-m, 1.8 lbf-ft) |
| License light cover screw | 1 N-m (0.1 kgf-m, 0.7 lbf-ft) |

Warranty Policy (Valid in India only)

Honda Motorcycle & Scooter India (Pvt.) Ltd. (HMSI) gives the following warranty in respect of vehicle **"SP 125"** manufactured by them.

Proper care and precaution has been taken to ensure the best quality in respect of the material and workmanship in manufacturing **"SP 125"**.

HMSI would repair or replace at its discretion, those part(s) found to have manufacturing defects during examination. This repair or replacement of part(s) would be done free of charge at their authorised workshop, within a warranty period of 36 months from the date of sale or until the vehicle has covered 42000kms, whichever comes first.

Warranty claims in respect of proprietary parts like tyres and battery are warranted by their respective manufacturers and should be claimed on them directly by customer.

NOTE: Battery Warranty is applicable from 21 months from Date Of Charging at manufacturer or 18 Months from the Date Of Sale or 20000 Kms whichever is earlier.

In all such cases the decision of the respective manufacturer will be final and binding.

HMSI shall not be liable in any manner to replace them though their dealers will give full assistance in preferring such claims on their manufacturers.

HMSI undertake no liability in the matter of consequential loss or damage caused due to the failure of the parts. Delay, if any, at the repairing workshop in carrying out repair to vehicle shall not be a ground for extending the warranty period nor shall it give any right to the customer for claiming any compensation for damages.

HMSI reserves the right either to repair or replace the defective part.

Where a defective part can be replaced by part/s of alternative brand/s, which are normally used by HMSI in the course of manufacturing, HMSI reserves the right to carry out the replacement by a part or parts of any such alternative brands.

Warranty Policy (Valid in India Only)

This warranty and any claim arising there from is subject to Gurgaon jurisdiction only.

No claim for exchange or repair can be considered unless the customer:

- a. Ensures that immediately upon discovery of the defect, he approaches any nearest authorised dealer of HMSI with the concerned vehicle and enables him to remove and dispatch the part/parts attributing to manufacturing defect to the company.
- b. Produces Owner's Manual in original, to enable that dealer to verify the details. It must be expressly understood that claims forwarded directly to us by the owner/customer will not be entertained at all and such defective part/parts thus forwarded by them will lie at our factory at their own risk, and this warranty shall not be enforceable.

Further this warranty is not applicable to:

1. Any **"SP 125"** on which any free and paid services has not been carried out, as per schedule given in Owner's Manual.
2. Normal maintenance operations like valve adjustment, cleaning of fuel system, engine tune-up or such other adjustments.
3. HMSI does not warrant normal wear and tear items like Clutch Disc, Chain, Chain Sprocket, Wheel Rim (in case of misalignment and bent), Bushes, Fasteners, Shims, Washers and Electrical Items like Bulbs, Rubber and Plastic Components like Grommets, O-Rings, Bellows as well as Packings, Gaskets, Oil Seals and Consumables like Fuel Filter, Air Cleaner Element, Engine Oil, Grease, Suspension Oil and other items as specified by HMSI.
4. Fasteners and clips which need replacement during maintenance/service will not be covered under warranty.

5. If there is any damage to the painted surface due to industrial pollution or other extraneous factors.
6. Any damage resulting from unavoidable natural disaster i.e fire collision, earthquake, flood etc.
7. Any damage caused by exposure of the product to soot and smoke, chemical agents, bird-droppings, sea water, sea breeze, or other environmental phenomenon.
8. If there is any damage caused due to usage of improper oil/grease, non genuine parts.
9. For two-wheelers, which have been used for any commercial purposes as taxi etc.
10. For maintenance repairs required due to misuse while driving or due to adulteration of oil, petrol or due to bad road conditions.
11. Recommended fuel quality not used.
12. Parts of the vehicle that have been subjected to misuse, accident, negligent treatment or which have been used in conjunction with parts and an equipment not manufactured or recommended for use by HMSI if in the sole judgment of HMSI, such use prematurely affects the performance and reliability of the vehicle.
13. Parts of the vehicle that have been altered or modified or replaced in unauthorised manner, and which in the sole judgment of HMSI affect its performance and reliability.
14. The vehicle that has not been serviced by HMSI authorised dealer as per the service schedule or which have not been operated or maintained in accordance with instructions mentioned in the Owner's Manual.
15. The vehicles used for any competition or race and/or for attempting to set up any kind of record HMSI reserves the right to make any changes in design or to add any improvement on the vehicle at any time without incurring any obligations to install the same on a vehicle previously supplied and sold. Also the conditions of this warranty are subject to alteration without any notice.

Warranty Policy (Valid in India Only)

This warranty is entirely written warranty given by HMSI for **"SP 125"** and no other person, including the dealer or its or his agent or employee is authorised to extend or enlarge this warranty.

This warranty is given in lieu of and excludes every condition or warranty whether statutory or otherwise not herein expressly set out.

EMISSION WARRANTY

Subject to other terms of the warranty policy and other conditions and obligations laid down hereunder, the manufacturer certifies that the components liable to affect the emission of the gaseous pollutants in the vehicle in normal use despite the use to which it may be subjected, comply with provisions of rule 115(2) of the Central Motor Vehicle Rules, 1989 and further warrants that if on examination by a service center duly authorized by the manufacturer, the vehicle is discovered to be failing to meet the emission standard as specified in the said rule,

the authorized service center shall take such corrective measures as may be necessary and shall at its sole discretion replace free of charge such components of emission control system as are specified in schedule.

A. Conditions

1. This warranty will be in addition to and run parallel to the product warranty given by the manufacturer and will apply to components as mentioned later. This warranty is applicable in Delhi, Mumbai, Kolkata and Chennai with effective from 1st July 2001. Other places when included will be covered under warranty accordingly.
2. The period of the vehicle's emission warranty will be determined starting from the date of the vehicle sale. The period of time and kilometers that are covered under the provisions of warranty may vary but should not be less than the minimum warranty period based on the vehicle category.

For a two-wheeler the emission warranty period is 30,000 kms or 3 years whichever is earlier.

3. Warranty claim for the components under Emission warranty will be admitted, for a prima facie examination, in the event of failure of the vehicle to meet the emission standard as specified in sub-rule (2) of Rule No 115 of the Central Motor vehicle Rules.
4. The warranty claim will be accepted only after the examinations carried out by Authorized Service Centers leads to a firm conclusion that none of the original settings have been tampered with and that the components has/have a manufacturing defect, and/or, that the vehicle is unable to meet the in-use emission standard, in spite of the vehicle being maintained and used in accordance with the instructions in the owner's manual.
5. The methods of examination to determine the warrantable condition of the components will be at the sole discretion of manufacturers and or their Authorized service centers and results of such examination will be final and binding. If, on examination, a warrantable condition is not established, the manufacturers will have to charge all, or part, of the cost of such examination.
6. In case of a vehicle in which the components covered under Emission warranty, the manufacturer will replace, at Authorized centers free of charge, the components which are covered, but the consumables as mentioned in Owner's Manual shall be charged as per actuals.
7. In case of a vehicle in which the components covered under Emission warranty or the associated parts are not independently replaceable on account of their being integral parts of a complete assembly, the manufacturer will have the sole discretion to replace either the entire assembly or by using some of the parts of the system through suitable repairs or modifications.

Warranty Policy (Valid in India Only)

8. Any consequential repairs or replacement of parts which may be found necessary to establish compliance to in-use emission standards, in addition to replacement of the parts covered under emission warranty, will not be made free of cost unless such parts are also found to be in a warrantable condition within the scope and limit of the product warranty. The consumables shall be charged as per actual during such repairs or replacement of parts.
9. All the parts removed for replacement under warranty will be the property of the manufacturer.
10. The manufacturer will not be responsible for the cost of transportation of the vehicle to the nearest Authorized Service center or any loss due to non-availability of the vehicle during the period of lodging of a warranty claim and examination by the manufacturer and repairs.
11. The manufacturer will not be responsible for any penalties that may be charged by statutory authorities on account of failure to comply with the in use emission standards.
12. Emission warranty will be applicable irrespective of the change of ownership of the vehicle provided all the conditions as laid down in this document are met from the date of original sale of the vehicle.
13. The emission warranty will be applicable only if:
 - a. Observes all the important instructions and any other precautions listed in the Owner's Manual for use of the vehicle.
 - b. Under all circumstances uses lubricants and fuel as recommended by manufacturer.
 - c. Regularly obtains and carries out maintenance in accordance with the manufacturers guidelines and enters the details in the Logbook.
 - d. Immediately approaches the nearest authorized service center upon discovery of failure to comply with the

- in use emission standards in spite of having maintained and used the vehicle in accordance with the instructions in the Owner's Manual and having carried out such repairs and adjustments as may be required with a view to establish such compliance.
- e. Produces the 'Pollution Under Control' certificate valid for the period immediately preceding the test during which the failure is discovered, the test having been carried out either for obtaining a new certificate, or pursuant upon being directed by an officer as referred to in sub-rule(2) of Rule 116 of the Central Motor Vehicle Rules.
 - f. Produces the Owner's Manual and Log book for verification details.
 - g. Produces receipts covering maintenance of the vehicle as specified in the Owner's Manual from the date of original purchase of the vehicle.
 - h. Produces valid certificate of insurance and RTO registration.
14. Conditions under which warranty is not applicable:
- A valid 'Pollution Under Control' certificate as described in customer obligation D(6) above is not produced.
 - A vehicle which is not serviced by Authorized service center as per the service schedule described in the maintenance chart given in the Owner's Manual.
 - A vehicle, which has been subjected to abnormal use, abuse, neglect and improper maintenance or has met with an accident.
 - Use of replacement parts not specified and approved by the manufacturer.
 - A vehicle, or parts thereof, which has been altered, tampered with or modified or replaced in an unauthorized manner.
 - A vehicle on which the odometer is not functioning or the odometer has been changed/tampered with so that the actual mileage cannot be readily determined.

Warranty Policy (Valid in India Only)

A vehicle which has been used for competitions, races, rallies or for the purpose of establishing records.

Examination by the manufacturers or his Authorized Service Centers of the vehicle shows that any of the conditions stipulated in the Owner's Manual with regard to use and maintenance have been violated.

A vehicle, which has been run on, adulterated fuel, leaded fuel or lubricant or fuel/lubricants other than those specified by the manufacturer in the Owner's Manual with regard to use and maintenance have been violated.

SCOPE AND LIMITS

1. This emission warranty is in addition to product warranty and shall run parallel to the product warranty for the vehicle as per the scope and limit described in the Owner's Manual and all conditions described there in will apply in addition to those exclusively stipulated in this warranty.

2. The emission warranty covers only compliance with the emission standard as specified in the sub rule (2) of rule 115 of CMVR. It does not cover any other performance of these parts or routine test and consequent maintenance or adjustments to establish compliance to the in use emission standard as applicable to the state, in which the vehicle is registered and is in use.

The parts, which are covered under emission warranty, are carburetor and internal parts, intake manifold, distributor and internal parts, ignition coil, muffler etc.

NOTE: The emission warranty is applicable only when a customer enters into emission warranty contract.

- A**
- Accessories..... 12
- B**
- Basic Operation Flow..... 14
- Battery..... 43, 53
- Brakes
 - Brake Lever Freeplay..... 68
 - Brake Pedal Freeplay..... 65, 69
 - Brake Light Switch..... 74
 - Fluid..... 63
 - Pad Wear..... 64
 - Shoe Wear..... 67, 73
- Braking..... 9
- Bulb
 - Brake/Tail Light..... 100
 - Front Turn Signal..... 101
 - Headlight..... 100
 - License Plate Light..... 101
 - Rear Turn Signal..... 101
- C**
- Caring for Your Vehicle..... 107
- Clutch..... 81
- Catalytic Converter..... 115
- Clock..... 19
- Compartment
 - Document Bag..... 35, 106
 - Owner's Manual..... 106
 - Tool Kit..... 35
- Crankcase Breather..... 84
- E**
- Electrical Trouble..... 99
- Engine
 - Number..... 113
 - Oil..... 46, 59, 117
 - Oil Filter..... 61
 - Starting..... 30
- Environment..... 112
- F**
- Frame Number..... 113
- Frame Brake Lever Adjustment..... 68
- Fuel
 - Gauge..... 19, 20
 - Recommended..... 34
 - Remaining..... 19
 - Tank Capacity..... 34
- Fuels Containing Alcohol..... 114

Fuses 45, 118

G

Gasohol 114
 Gear Position Indicator 19

H

Headlight Aim 85
 Headlight Dimmer Switch 27
 Helmet Holders 36
 High Beam Indicator 25
 Horn Button 27

I

Ignition Key 105
 Ignition Switch 27, 28
 Image Labels 6
 Indicators 25
 Instruments 18

K

Keys 105

L

Labels 6
 Load Limits 13

Loading Guidelines 13

M

Maintenance

Fundamentals 42
 Importance 38
 Safety 38
 Schedule 39

Maximum Weight Limit 13, 116

Modifications 12

N

Neutral Indicator 19

O

Odometer 19, 20, 116

Oil

Engine 46, 59, 117

P

Parking 10

Parts Location 16

Petrol 11, 34, 116

PGM-FI (Programmed Fuel Injection)

Malfunction Indicator Lamp (MIL) 25, 89

Protective Apparel 8

| | |
|--------------------------------|---------|
| R | |
| Recommended | |
| Fuel..... | 34 |
| Oil..... | 46 |
| Refueling..... | 34 |
| Removal | |
| Battery..... | 53 |
| Drive Chain Case..... | 54 |
| Seat..... | 55 |
| Side Cover..... | 56 |
| Riding Precautions..... | 9 |
| S | |
| Safety Precautions..... | 8 |
| Seat..... | 55 |
| Serial Numbers..... | 113 |
| Side Stand..... | 75 |
| Spark Plug..... | 57 |
| Specifications..... | 116 |
| Speedometer..... | 19 |
| Start Button..... | 27 |
| Starting the Engine..... | 30 |
| Starting the Vehicle..... | 40 |
| Steering Lock..... | 28 |
| Storage Equipment..... | 35 |
| Storing Your Vehicle..... | 110 |
| Switches..... | 27 |
| T | |
| Throttle..... | 83 |
| Tool..... | 52 |
| Transporting Your Vehicle..... | 111 |
| Tripmeter..... | 19 |
| Troubleshooting..... | 87 |
| Turn signal indicators..... | 25 |
| Tyres | |
| Air Pressure..... | 49, 117 |
| Puncture..... | 91 |
| Replacing..... | 49, 91 |
| W | |
| Warning Indicator On..... | 89 |
| Warranty Policy..... | 119 |
| Washing Your Vehicle..... | 107 |
| Weight Limit..... | 13 |
| Wheels | |
| Front Removal..... | 92 |
| Rear Removal..... | 96 |